

# FMTV A1 R M1147 A1

## Load Handling System (LHS) Trailer

The Family of Medium Tactical Vehicles (FMTV) provides the U.S. Army's backbone for tactical unit mobility and logistics support throughout the battlefield. These vehicles are considered the most sophisticated off-road, multi-purpose military tactical vehicles in use, and are capable of operating worldwide on primary and secondary roads, as well as on trails and cross-country in weather extremes from -50°F (-46°C) to +120°F (49°C).

### Product Numbers

LIN Z00252

NSN 2330-01-508-7887

### KEY FEATURES

Electronic Central Tire Inflation System (CTIS)

Anti-lock Braking System (ABS)

Interactive Electronic Technical Manuals (IETM)

Fully MANPRINT compliant

C-130 air transportable at GVW

U.S. Army proven ultra-reliability

Family of 16+ vehicles with 80% commonality

U.S. Army certified 22-year corrosion protection

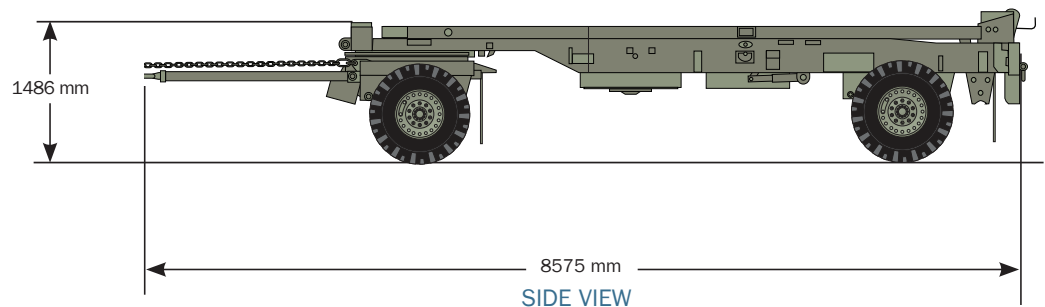

# FMTV A1 R M1147 A1

## Load Handling System (LHS) Trailer

### VEHICLE SPECIFICATIONS

|  |   |
|--|---|
| Length:                                    |   |
| Frame Only                                 | 261.9 in (6,652 mm)                       |
| Total Length<br>(Including Drawbar)        | 337.6 in (8,575 mm)                       |
| Width:                                     |   |
| Transport<br>ISO Container or<br>Flat Rack | 95.9 in (2,438 mm)<br>101.7 in (2,583 mm) |
| Height:                                    |   |
| Overall<br>Deck                            | 58.5 in (1,486 mm)<br>47.5 in (1,207 mm)  |
| Wheel Base:                                | 183.5 in (4,661 mm)                       |
| Ground Clearance:<br>(Minimum)             | 14.5 in (368 mm)                          |
| Departure Angle:                           | 30°                                       |
| Trailer Curb Weight:                       | 9,480 lb (4,300 kg)                       |
| Payload:                                   | 18,000 lb (8,165 kg)                      |
| Maximum Grade:                             | 30%                                       |
| Maximum Side Slope:                        | 30%                                       |
| Fording (Without Kit):                     | 30 in (762 mm)                            |

### EQUIPMENT SPECIFICATIONS

|                               |   |
|-------------------------------|---|
| Tires:                        | Michelin XTY275/70R22.5   |
| Brakes:                       | 16.5 X 7 S-Cam Type with ABS  |
| Suspension:                   | Air Ride, Air Pressure Sensor Gages<br>for Overload Indication  |
| Payload Modules:              |   |
| Flatracks                     | M1 & M1077 per STANAG 2413<br>CROP M3 & M3A1  |
| ISO Containers                | 20 ft (6 m) Long with 8 ft (2.4 m)<br>or 8.5 ft (2.6 m) Height  |
| Medical Shelters              | 20 ft (6 m) Long Aluminum<br>Expansible Shelters  |
| Key Dimensional Requirements: |   |
|                               | Capable of Negotiating a 13 ft (4 m)<br>Underpass with an Empty 20 ft (6 m) Long,<br>8.5 ft (2.6 m) high ISO Container.<br>Transportable by C-130 When Stacked as a<br>Vertical Unit of Two Trailers. |

### FOR MORE INFORMATION CONTACT:

BAE Systems  
5000 I-10 West  
Sealy, TX 77474 USA  
Telephone 281-856-0139  
Toll Free 866-390-1944  
Fax 979-885-7910  
Email mhvehicles@baesystems.com  
www.baesystems.com

This document gives only a general description of the product(s) or services and except where expressly provided otherwise shall not form part of any contract. From time to time, changes may be made in the products or the conditions of supply. BAE Systems reserves the right to change product specifications without prior notice.