

FMTV A1 R M1095 A1

5.0 ton Trailer

The Family of Medium Tactical Vehicles (FMTV) provides the U.S. Army's backbone for tactical unit mobility and logistics support throughout the battlefield. These vehicles are considered the most sophisticated off-road, multi-purpose military tactical vehicles in use, and are capable of operating worldwide on primary and secondary roads, as well as on trails and cross-country in weather extremes from -50°F (-46°C) to +120°F (49°C).

Product Numbers

LIN T95555

NSN 2320-01-449-1776

KEY FEATURES

Electronic Central Tire Inflation System (CTIS)

Anti-lock Braking System (ABS)

Interactive Electronic Technical Manuals (IETM)

Fully MANPRINT compliant

C-130 air transportable at GVW

U.S. Army proven ultra-reliability

Family of 16+ vehicles with 80% commonality

U.S. Army certified 22-year corrosion protection

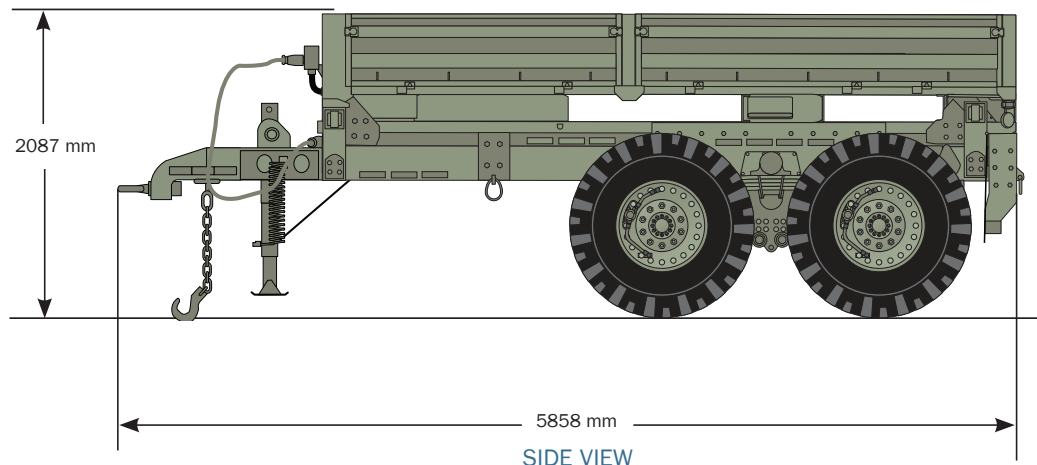

FMTV A1 R M1095 A1

5.0 ton Trailer

VEHICLE SPECIFICATIONS

Length:	
Overall	230.5 in (5,855 mm)
Cargo Bed (Inside)	170.2 in (4,324 mm)
Width:	
Overall	96 in (2,438 mm)
Cargo Bed (Inside)	91.5 in (2,324 mm)
Height:	
Overall	82.2 in (2,087 mm)
For Air Transport	82.2 in (2,087 mm)
Deck Height:	
Empty	63.8 in (1,620 mm)
Loaded	60 in (1,524 mm)
Ground Clearance:	
Empty	14.5 in (368 mm)
Loaded	12.3 in (312 mm)
Departure Angle:	47°
Vehicle Curb Weight (VCW):	
	10,128 lb (4,594 kg)
Gross Vehicle Weight (GVW):	
	20,128 lb (9,130 kg)
Tongue Weight:	
At VCW	1,080 lb (490 kg)
At GVW	2,216 lb (1,005 kg)
Payload:	10,000 lb (4,536 kg)
Maximum Grade:	30%
Side Slope:	30%
Fording:	30 in (762 mm)

EQUIPMENT SPECIFICATIONS

Axles:	ArvinMeritor Dual
Brakes:	Air-Activated Internal Expansion with Anti-Lock Braking System (ABS)
Electrical System:	12/24 volt with Blackout
Tires:	Michelin 395/85R20XML All-Terrain
Suspension:	High Travel Double Axle Leaf Parabolic Spring with Anti-Sway Bar
Transportability/Deployability:	
Internally	Airdrop (LVAD) and Air Transportable by C-130, C-141, C-17, and C-5A at GVW
Externally	Transportable by CH-47 and CH-53 Helicopters with Integral Sling Bars
Cargo Bed:	
Construction	All Steel, E-COAT Rustproofing Dropside with Side Rail Storage
Ladder	Integral, Stowed
Optional	Bows and Tarp Kit

FOR MORE INFORMATION CONTACT:

BAE Systems
 5000 I-10 West
 Sealy, TX 77474 USA
 Telephone 281-856-0139
 Toll Free 866-390-1944
 Fax 979-885-7910
 Email mhvehicles@baesystems.com
 www.baesystems.com

This document gives only a general description of the product(s) or services and except where expressly provided otherwise shall not form part of any contract. From time to time, changes may be made in the products or the conditions of supply. BAE Systems reserves the right to change product specifications without prior notice.