

**THEATER MISSILE DEFENSE TARGETS FOR
INTERCEPTOR TEST AND EVALUATION**

**Major Nat Thongchua
Ballistic Missile Defense Organization
Washington, D.C. 20301**

**Michael Kaczmarek
SRS Technologies
Arlington, VA 22209**

**1994 AIAA Missile Sciences Conference
November 7-9, 1994
Monterey, California**

19941206 037

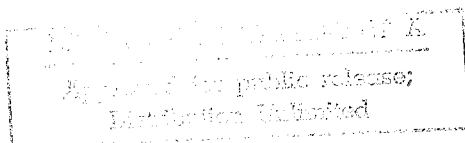

THEATER MISSILE DEFENSE TARGETS FOR
INTERCEPTOR TEST AND EVALUATION

Major Nat Thongchua*
Ballistic Missile Defense Organization
Washington, D.C. 20301

Mr. Michael Kaczmarek†
SRS Technologies
Arlington, VA 22209

Accession For		
NTIS	CRA&I	<input checked="" type="checkbox"/>
DTIC	TAB	<input type="checkbox"/>
Unannounced		<input type="checkbox"/>
Justification		
By		
Distribution /		
Availability Codes		
Dist	Avail and/or Special	
A-1		

Abstract

A well defined, planned, and executed Test and Evaluation (T&E) program is critical to the successful acquisition of Theater Missile Defense (TMD) interceptor and sensor programs. One of the items associated with a credible T&E environment, which is continuously being assessed for realism or fidelity, is the target being used to evaluate the interceptor, sensor, and integrated experiment performance. This paper provides a brief backdrop to the description of TMD targets by defining the Ballistic Missile Defense Organization (BMDO) Consolidated Targets Program (CTP) and by organizing targets into threat categories.

I. Consolidated Targets Program

Several years ago, The BMDO, formerly the Strategic Defense Initiative Organization (SDIO), consolidated their target programs. This initiative has facilitated improved management of target requirements, validation, verification, & accreditation (VV&A) processes, and acquisition of expendable and support systems. Consolidation has accomplished the obvious by reducing duplication of effort and taking advantage of economy of scale. It has also proven itself by efficiently developing test target scoring systems required for lethality assessments by all interceptor programs and by saving time and effort in accomplishing environmental studies based on integrated program test planning.

II. Current Threat Set

The current target set is designed to represent two levels of threat systems for interceptor

and sensor program testing: short range threats, and medium range theater threats. Of these targets, STORM, HERA, Foreign Materiel Assets, and other target systems such as the Strypi IX and the Lance, are expected to perform within treaty and range constraints while achieving testing objectives. These threat levels for TMD are defined with their corresponding target systems in Table 1:

Threat Level	Target System
Short Range Theater Threat	STORM FMA Other Targets
Medium Range Theater Threat	HERA FMA Other Targets

Table 1: TMD Threat Systems

Overall, the performance and physical characteristics of these targets cover a wide range of theater threat systems (see Figure 1) and can be configured to more closely represent a particular threat system. The choice of target to be used however is highly dependent on the interceptor or sensor program testing objectives.

III. STORM

The STORM target system, shown in Figure 2, has been developed by Orbital Sciences Corporation through USASSDC for the BMDO and served as the core theater ballistic missile target system for testing of the Patriot and Extended Range Interceptor (ERINT) systems during their test phases.

The STORM is a two stage booster system that has the capability to perform as both a

* Program Integrator, Targets, BMDO
† Aerospace Engineer, AIAA Member

Ballistic Tactical Target Vehicle (BTTV) and a Maneuvering Tactical Target Vehicle (MTTV). It consists of a Sergeant XM100 first stage booster, a M57A1 second stage booster, two interstage adapters, and a Guidance and Control Assembly (GCA) Module, Figure 3. The STORM was designed to simulate the performance of short range theater threat systems. For this reason, its systems can be modified in order to better suit specific missions.

The STORM first stage, the Sergeant XM100, is a single nozzle booster developed by Thiokol Corporation. It was originally designed for use as a surface-to-surface booster for the Sergeant missile system in 1961. The Sergeant XM100 is equipped with an aft skirt assembly containing three Pershing 1A jet vane/air vane (articulated aileron type air vanes mounted in tailfins) and hydro-pac actuator assemblies. Physical and performance characteristics of the Sergeant XM100 can be found in Table 2. An illustration of the Sergeant XM100 can be found at Figure 4 with performance graphs at Figures 5, and 6.

Characteristic	Value
Length	4.98 m
Diameter (motor)	0.79 m
Diameter (base)	1.02 m
Total Weight	3,134 kg
Propellant	TP-E8057
Propellant Mass	2,676 kg
Average Thrust	187.1 kN
Isp	184 sec
Avg. Chamber Pressure	3,696 kPa
Nozzle Exit Area	0.20 m ²
Avg. Nozzle Expansion Ratio	6:1
Avg. Mass Flow	112.4 kg/sec
Burn Time (nominal)	23.8 sec
Steering/Stabilization	Inertial

Table 2: Sergeant XM100 Physical & Performance Characteristics

The STORM second stage, the M57A1, is a Minuteman I and II third stage booster developed by Hercules Powder Company. The M57A1 is equipped with an explosive thrust termination system which allows the STORM target to fly multiple trajectories of varying ranges and velocities within the confines of White Sands Missile Range (WSMR). Physical

and performance characteristics of the M57A1 can be found in Table 3. An illustration of the M57A1 can be found at Figure 7 with performance graphs at Figures 8, and 9.

Characteristic	Value
Length	2.17 m
Diameter (motor)	.96m
Total Weight	1,927 kg
Propellant	CYH-77/ DDP-77
Propellant Mass	1,659 kg
Average Thrust @ 60° F	76.6 kN
Isp @ 35 km	276 sec
Avg. Chamber Pressure @ 60° F	1689 kPa
Nozzle Exit Area	0.46 m ²
Avg. Nozzle Expansion Ratio	18.4:1
Avg. Mass Flow	28.1 kg/sec
Burn Time (nominal)	59.0 sec
Steering/Stabilization	Thrust Vector Control (TVC)

Table 3: M57A1 Physical & Performance Characteristics

The combination of these two motors allows the STORM target to fly at a velocity of approximately 1.5 km/sec with a range that can readily exceed 500 km with minimal payload. Physical and performance characteristics of the STORM target system can be found in Table 4 and typical performance for the BTTV can be found in Figure 10.

Characteristic	Value
Length	13.28 m
Diameter	1.02 m
Total Weight (with 1,689 kg Payload)	7,048 kg
Usable Payload Mass (BTTV)	842 kg
Usable Payload Mass (MTTV)	680 kg
Payload Diameter	1.0 m
Range @ WSMR	130 km
Altitude @ WSMR	170 km
Velocity @ WSMR	~1.5 km/sec
Launch Sites	WSMR LC-36 and Sulf Site
Launch Mode	Stool

Table 4: STORM Physical & Performance Characteristics

The STORM BTTV is a threat representative reentry vehicle approximately 3.3 meters in length and approximately one meter in diameter that can be configured to perform with either a high or low Radar Cross Section (RCS) depending on the mission objectives. The BTTV is capable of carrying either a Bulk Chemical Experiment (BCE) payload (Figure 11) composed of 189kg of TEM/PMMA chemical simulants or a Submunition Chemical Experiment (SCE) payload (Figure 12) made up of 38 canisters arranged within three tiers of 10, 10, and 12 over 6 substacks.

The MTTV version of the STORM system is made up of a modified Pershing II RV as its front end (Figure 13). The Pershing II RV is the only available maneuvering treaty-compliant U.S. Theater Ballistic Missile RV.

STORM flies most of its missions out of Sulf Site at the White Sands Missile Range in New Mexico (WSMR) (Figure 14). It has performed as a target for intercept for both the PATRIOT Advanced Capability (PAC-2) and PATRIOT Multi-Mode Seeker Demonstration (MMSD). It has also been successfully intercepted by the Extended Range Interceptor (ERINT) target system on two occasions. A history of the STORM target flights is provided in Table 5

Milestone	Date
STORM BTTV-1 Demo	17 January 1992
STORM BTTV-2 Demo	15 May 1992
STORM BTTV-3 Demo	4 February 1993
PATRIOT PAC-2	8 October 1993
PATRIOT MMSD-3	26 October 1993
ERINT GTF-2	30 November 1993
STORM MTTV-1 Demo	17 December 1993
ERINT GTF-3	15 February 1994

Table 5: STORM Flight History

IV. HERA

The HERA missile system, currently under development for the BMDO through USASDC by Coleman Research Corporation, is intended as the primary target for the testing of the Patriot Advanced Capability-3 (PAC-3) interceptor system during its Engineering and Manufacturing Development (EMD) phase and for the Theater High Altitude Area Defense

(THAAD) interceptor system during its DEM/VAL and early EMD phase.

The HERA is a two stage booster system made up of spare Minuteman components. The first stage is composed of a MinuteMan II second stage SR-19-AJ-1 motor developed by Aerojet, a 1st/2nd interstage adapter, and a flare. The SR-19 is a single nozzle motor which was an upgrade to the original Minuteman I second stage booster, the M56A1, for the Minuteman II and III. A flexseal modification, performed on the nozzle, allows the SR-19 to operate at sea level conditions necessary for interceptor testing. Physical and performance characteristics of the SR-19 can be found in Table 6. An illustration of the SR-19 can be found at Figure 15 with a performance graph at Figure 16.

Characteristic	Value
Length	4.32 m
Diameter (motor)	1.32 m
Diameter (base of flare)	1.63 m
Total Weight	7,201.4 kg
Propellant	ANB-3066
Propellant Mass	6,252.6 kg
Average Thrust	262.9 kN
Isp	297.3 sec
Avg. Chamber Pressure	3,068 kPa
Nozzle Exit Area	1.17 m ²
Avg. Nozzle Expansion Ratio	24.8:1
Avg. Mass Flow	93.3 kg/sec
Burn Time (nominal)	65.0 sec
Steering/Stabilization	TVC

Table 6: SR-19 Physical & Performance Characteristics

The second stage of the HERA system is composed of the M57A-1 booster which is the same booster used on the STORM target vehicle.

The HERA is intended to be a versatile target system capable of emulating a wide variety of threat systems in either a ballistic reentry vehicle (BRV) mode or a maneuvering target vehicle (MTV) mode. In order to encompass this wide range of threats, the HERA has been designed with the ability to perform as one of five variations within three configurations. These configurations are designated as Block I, Block II, and Block III (Figure 17).

The Block I version of the HERA is designated the BRV Conventional. The Block I consists of a Bulk Chemical Experiment (BCE) payload (Figure 18) which separates from the M57A-1 and the Guidance and Control Section (GCS). The Block I HERA will fly a nominal, or Conventional, trajectory at WSMR from either Launch Complex-32 (LC-32) or Firing In Extension (FIX) from the north addition to WSMR with a maximum range of approximately 120 km (Figures 19 & 20). Physical and performance characteristics of the HERA Block I system are provided in Table 7.

Characteristic	Value
Length	11.5 m
Diameter	~1.32 m
Total Weight (no ballast)	10,520 kg
Total Weight (full ballast)	11,700 kg
Reentry Vehicle Mass (nominal)	885 kg
Burnout Angle	35 degrees
Burnout Velocity	2.8 km/sec
Descent Velocity at 80 km	2.9 km/sec
Range	1040 km
Exo-Time (above 100 km)	396 sec
Launch Sites	WSMR & KTF
Launch Mode	Stool, Rail, Ship

Table 7: HERA Block I Physical & Performance Characteristics

The Block II can be modified to perform in one of three configurations: the BRV mode, the BRV-GCS mode, and the Unitary mode. The BRV version of the Block II is similar to the Block I BRV Conventional except that it is capable of carrying a submunitions payload within the BRV (Figure 21). The BRV-GCS version of the Block II allows the BRV and the GCS package to reenter as a single unit. This is done to represent a higher RCS threat system and also increase reentry velocity and IR characteristics. Both of these modes of the Block II will fly a conventional trajectory (Figures 18 & 19). The final version of the Block II is the Unitary configuration. The Unitary configuration allows the HERA system to represent more extended range and higher RCS threats by having the M57A-1 remain attached to the BRV-GCS during descent. The Block II Unitary can fly two different types of trajectories: a conventional trajectory, and a Pile Driver trajectory. The con-

ventional trajectory for the Block II Unitary is the same trajectory for the other HERA configurations. The Pile Driver trajectory from either LC-32 or FIX (Figures 22, 23 & 24) reorients the target and ignites the M57A-1 second stage booster at apogee allowing it to descend at a higher velocity and increased reentry angle. This trajectory will allow the HERA to represent the trajectories of many extended range threat systems while remaining within the confines of WSMR.

The Block III of the HERA target is designated as the MTV. The MTV uses a modified version of the Pershing II RV, similar to the MTTV used on STORM, as a baseline and is designed to accommodate a BCE (Bulk Chemical Experiment) payload (Figure 25).

Modifications to the HERA design are being performed in order to better emulate threat characteristics. Some of the modifications being made are in the areas of RV RCS reduction, RCS signature modifications, and booster maneuvering. The HERA target is expected to launch its demonstration flight in 2QFY95 at which time it will be certified for testing for the THAAD and Patriot PAC-3 interceptor programs.

V. Other Targets

Besides the STORM and HERA, the BMDO utilizes additional target systems in order to satisfy interceptor and sensor testing objectives. The utilization of these "other" targets is dependent on the level of threat fidelity required by an interceptor or sensor program. If this level is low, the requirement for a high fidelity threat representative target, like STORM and HERA, may be unnecessary. For this reason, the use of a lower fidelity system may be satisfactory in meeting the program requirements and be much more cost effective in the end.

Current requirements in BMDO call for the use of two of these "other" target systems: the Lance, and the Strypi IX.

The Lance target system (Figure 26) is a two stage mobile surface-to-surface battlefield support missile originally deployed through the U.S. Army in the continental U.S, Europe, and its allies. The Lance uses two liquid propellant

P8E6 motors, developed by Rocketdyne, capable of being stored fully fueled and ready for use (More information on the P8E6 motor can be found in Reference 8). It has a self contained, directional and velocity controlled guidance system and is capable of flying ranges from 8 to 130km depending on the warhead weight. The Lance is currently scheduled to be used as a target for the Navy's Sea Based Area Theater Ballistic Missile Defense (TBMD) Program beginning in 1996. Physical and performance characteristics of the Lance are provided in Table 8 with performance graph provided in Figures 27 & 28.

Characteristic	Value
Length	6.1 m
Diameter	0.56 m
Total Weight	1,527 kg
Max. Usable Payload Weight	455 kg
Payload Diameter	0.5m
Launch Sites	WSMR
Launch Mode	Transportable Launcher
Range (Max)	130 km
Apogee	45.6 km
Velocity (Max)	1.13 km/sec
Total Burn Time	200 sec

Table 8: Lance Physical & Performance Characteristics

The Strypi IX target system (Figure 29) is a two-stage sounding rocket, developed by Sandia National Laboratories, used for re-entry research programs and as a target for orbital sensors. The Strypi IX consists of an TX-33-39 Castor I motor in conjunction with two XM-19 Recruit strap-on motors, both developed by Thiokol Corporation, as its first stage. The second stage is made up of the X259 A2 Antares II booster, manufactured by Hercules Powder Company (See Reference 8 for more information). The Strypi IX is currently scheduled to be used as a target for the Navy's Extended Tracking and Control Experiment as part of their Sea Based Area TBMD Program in 1995. Physical and performance characteristics of the Strypi IX are provided in Table 9 with performance graphs provided in Figures 30 & 31.

Characteristic	Value
Length	11.4 m
Diameter	0.79 m
Total Weight	5,600 kg
Max. Usable Payload Weight	272 kg
Launch Sites	Wallops Is.; Kauai Test Facility; Johnson Is.; Poker Flats
Launch Mode	Rail Launcher
Range (Max)	1100 km
Apogee (Max)	400 km
Velocity (Max)	3.3 km/sec

Table 9: Strypi IX Physical & Performance Characteristics

VI. Foreign Materiel Acquisition (FMA)

In order to test the full capabilities of an interceptor, it is necessary to provide additional threat vehicles to further stress the interceptor system. The use of actual threat target vehicles is being considered for this purpose. The Foreign Material Acquisition Program (FMAP) is currently examining the purchase of foreign material assets to provide the tester with actual threat scenarios. Also, a study is being conducted which will investigate inexpensive target vehicles as optional threat-like objects.

VII. Conclusion

Although the choice of target systems remains highly dependent on the interceptor or sensor system program objectives, the CTP provides a baseline of modifiable systems capable of satisfying test phase requirements.

REFERENCES

1. "Program Introduction for HERA." U.S. Army Space and Strategic Defense Command. Huntsville, AL. April 1994.
2. "Final Environmental Impact Statement for the Strategic Target System." U.S. Army Space and Strategic Defense Command. Huntsville, AL. February 1992.

4. "Compendium of Target Systems." Targets Reliance Office. Point Mugu, CA. August 1994.

5. "STORM Ballistic Tactical Target Vehicle (BTTV) Critical Design Review (CDR)." Orbital Sciences Corporation. Chandler, AZ. July 20, 1994.

6. "Theater Missile Defense: HERA Target Systems." U.S. Army Space and Strategic Defense Command. Huntsville, AL. January 7, 1994.

7. "Theater Missile Defense (TMD) Targets Program: Preliminary Design Review (PDR) - Range B." Coleman Research Corporation. Orlando, FL. CDRL A00R. May 18 - 20, 1993.

8. "Launch Vehicles Reference Guide." U.S. Army Space and Strategic Defense Command. Huntsville, AL. October 1992.

9. "Maneuvering Tactical Target Vehicle (MTTV) Technical Interchange/Technical Direction (TI/TD)." Orbital Sciences Corporation. Chandler, AZ. May 13, 1993.

10. "The Test and Experiment Activity Summary Database." Ballistic Missile Defense Organization, Test and Evaluation Directorate. Washington, D.C.

11. "STORM Validation Report." SECRET. U.S. Army Space and Strategic Defense Command. Huntsville, AL. 28 August 1993.

12. "HERA Validation Report." SECRET. U.S. Army Space and Strategic Defense Command. Huntsville, AL. September 1994.

13. Thongchua, N. Liston, M. Kaczmarek, M. "Theater Missile Defense Target Fidelity." SECRET. AIAA/BMDO 3rd Annual Interceptor Technology Conference. July 11 - 14, 1994.

14. "Lance Feasibility Study: Final Report." SRS Technologies. Albuquerque, NM. September 30, 1992.

15. "Lance Field Artillery Missile System Briefing." Ballistic Missile Defense Organization. March 29, 1994.

16. Wilson, A., ed. "Jane's Space Directory: 1993-94." Jane's Information Group Limited. Alexandria, VA. 1993.

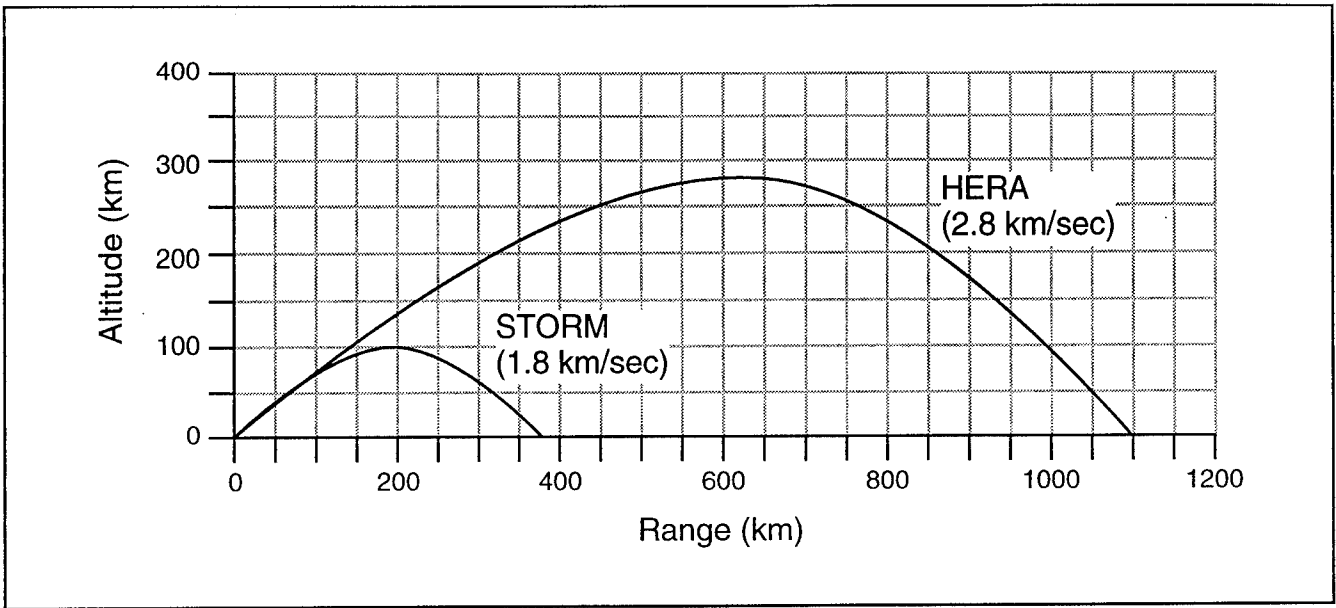

Figure #1: Theater Target Trajectories

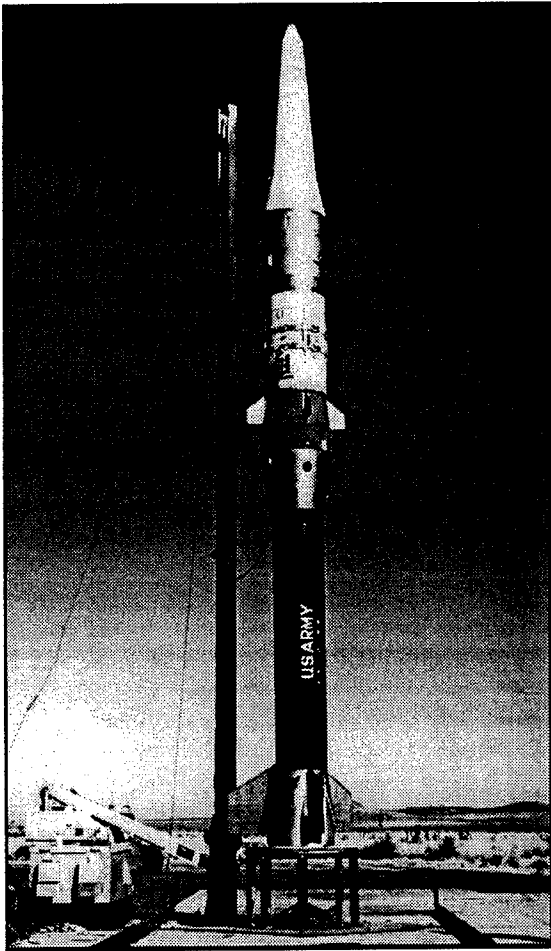

Figure 2: STORM Target System

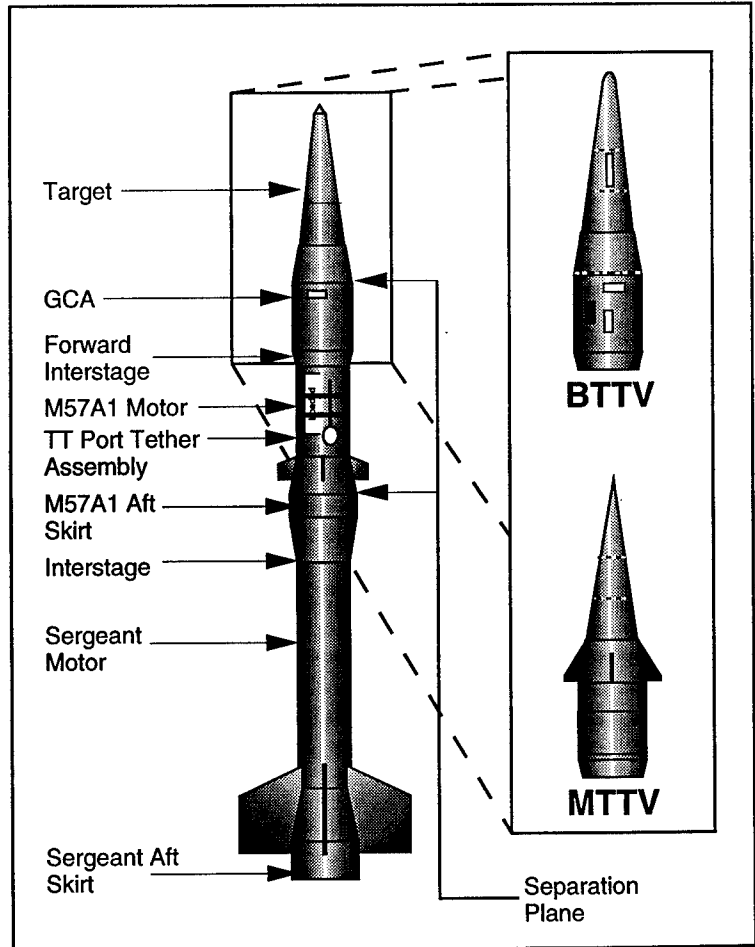

Figure 3: STORM Target System Components

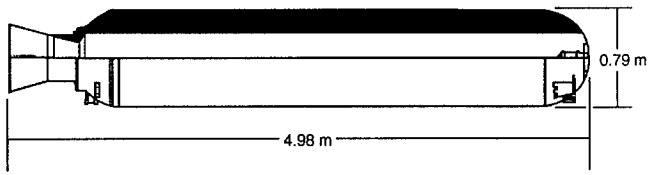

Figure 4: Sergeant XM100 Booster

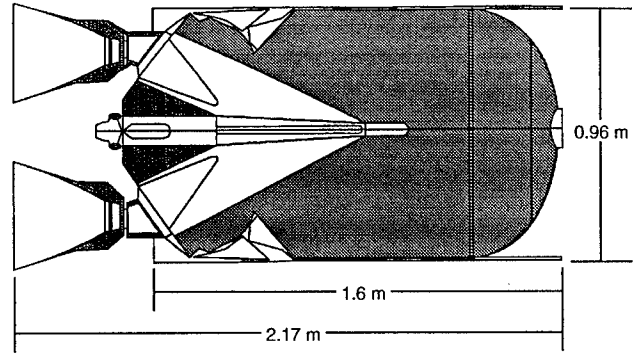

Figure 7: M57A1 Booster

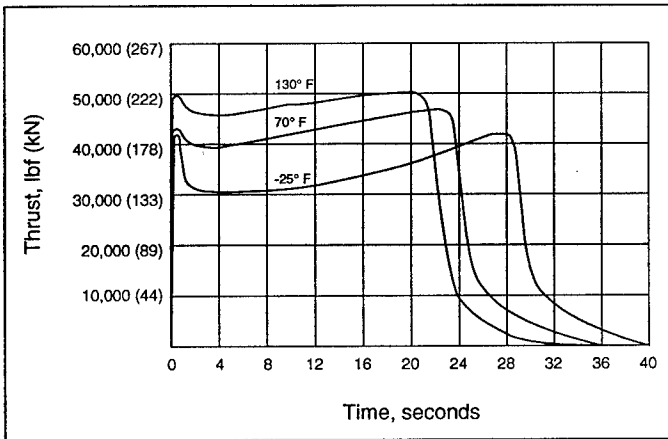

Figure 5: Sergeant XM100 Thrust vs. Time

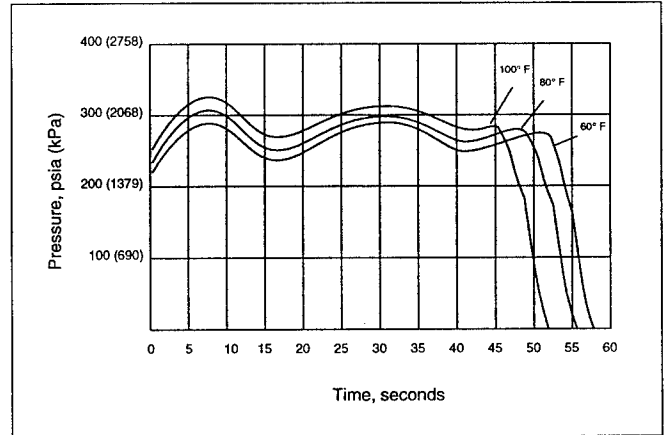

Figure 8: M57A1 Pressure vs. Time

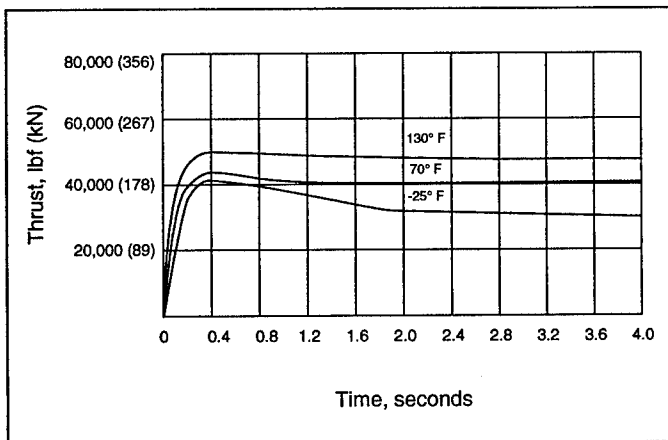

Figure 6: Sergeant XM100 Thrust vs. Time (Initial 4 Seconds)

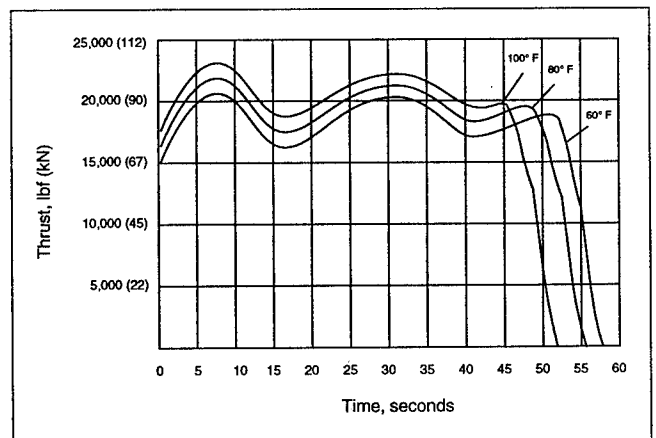

Figure 9: M57A1 Thrust vs. Time

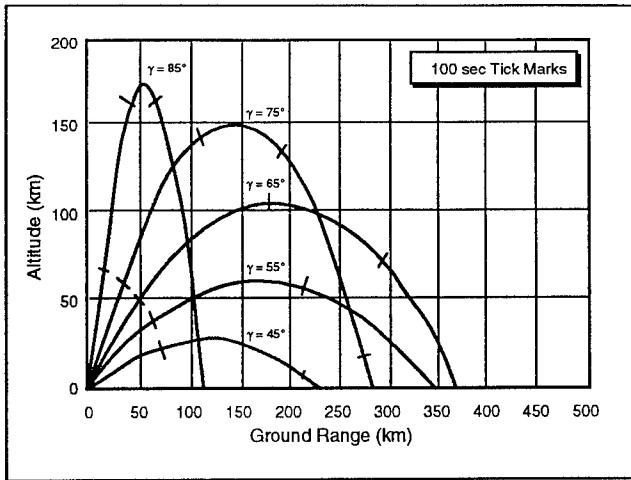

Figure 10: STORM BTTV Typical Performance

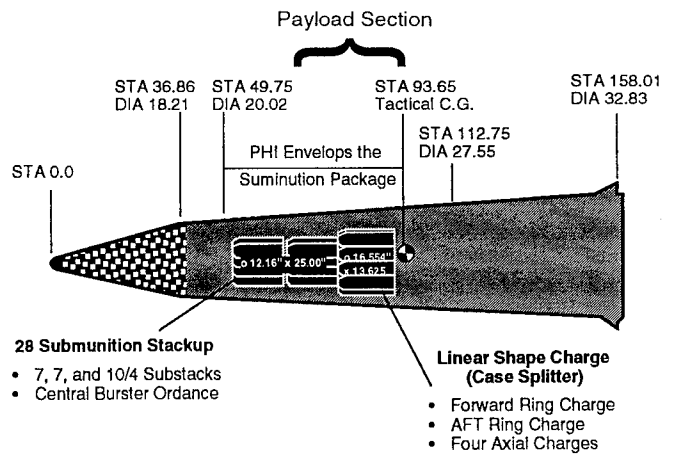

Figure 13: STORM MTTV

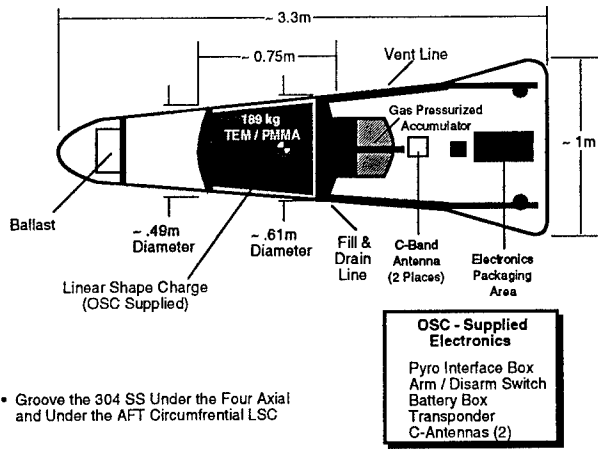

Figure 11: STORM BTTV Bulk Chemical Experiment Reentry Vehicle

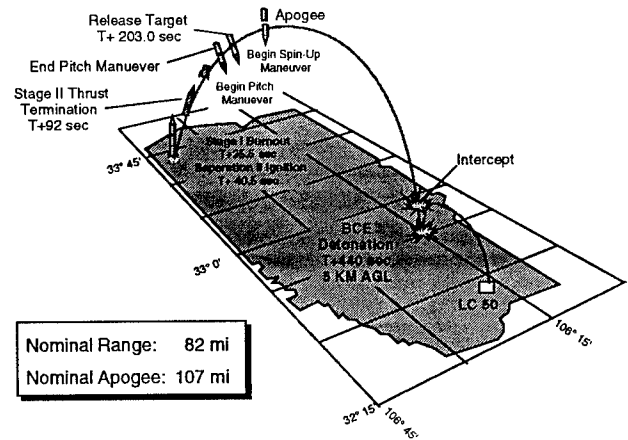

Figure 14: STORM BTTV Mission Overview at WSMR

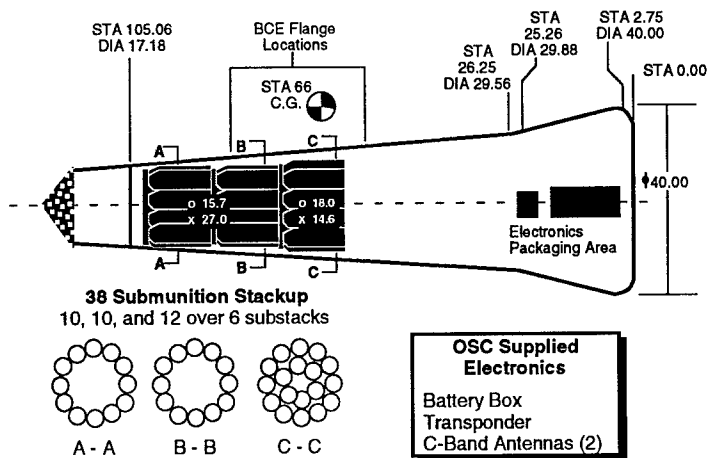

Figure 12: STORM BTTV Submunition Chemical Experiment Reentry Vehicle

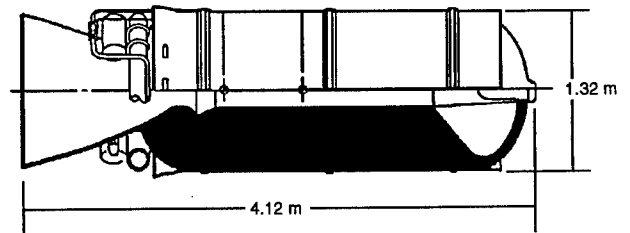

Figure 15: SR-19-AJ-1 Booster

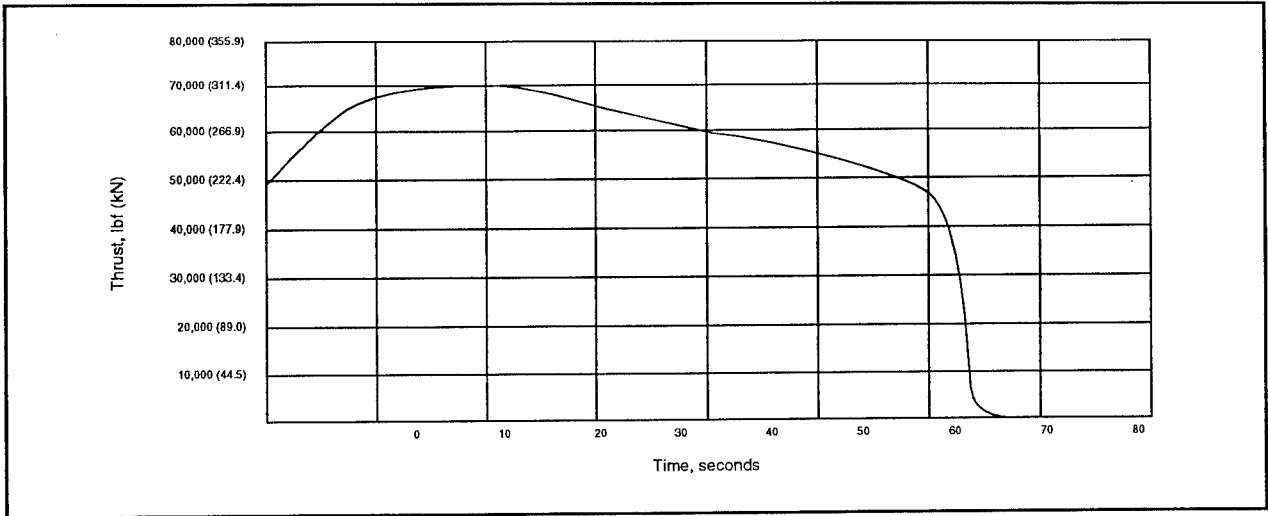

Figure 16: SR-19-AJ-1 Thrust vs. Time

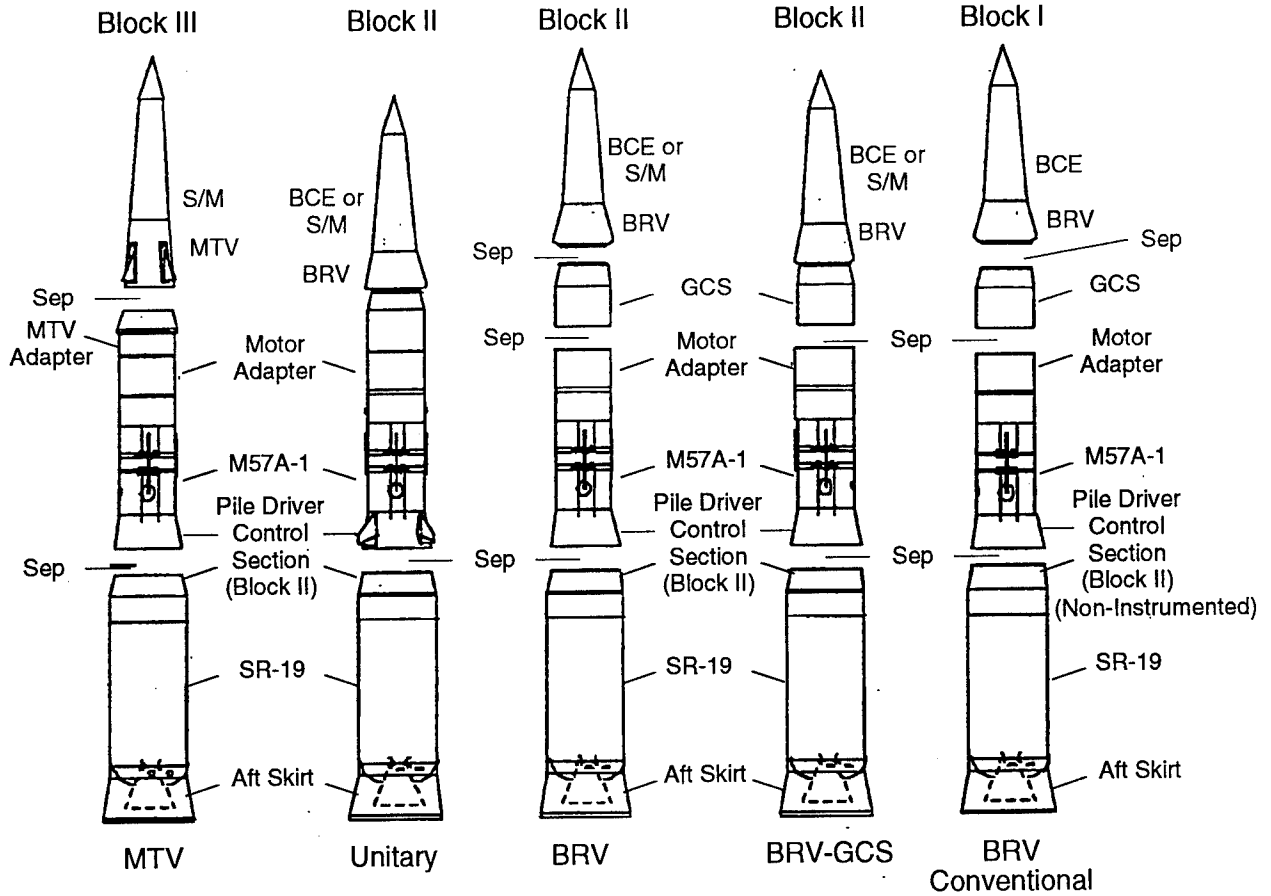

Figure17: HERA Target Configurations

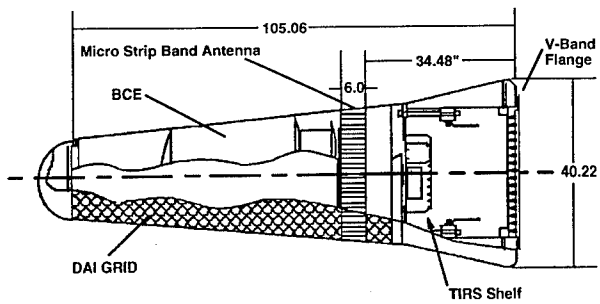

Figure 18: HERA BRV-BCE

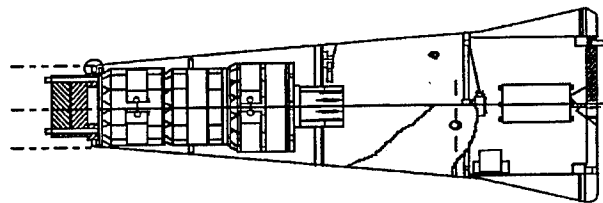

Figure 21: HERA Submunitions BRV (BRV-S/M)

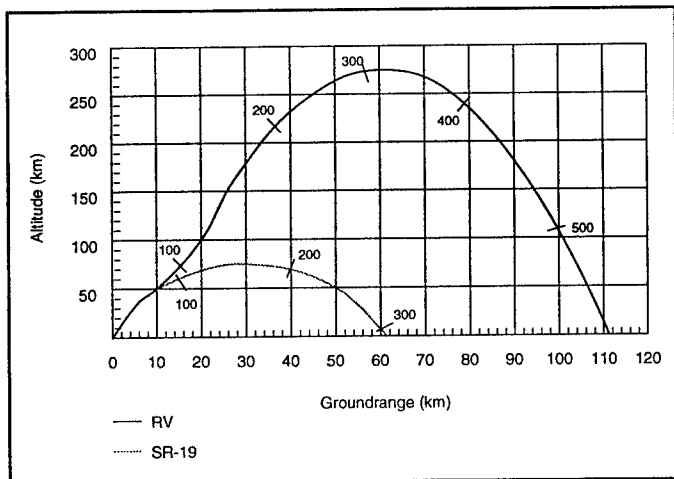

Figure 19: LC-32 Conventional Trajectory for HERA

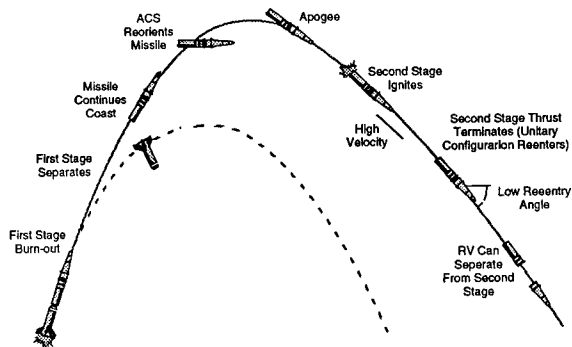

Figure 22: Pile Driver Concept

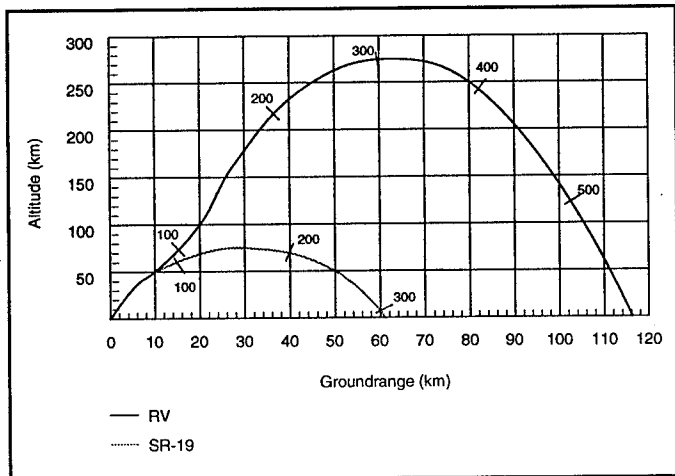

Figure 20: FIX Conventional Trajectory for HERA

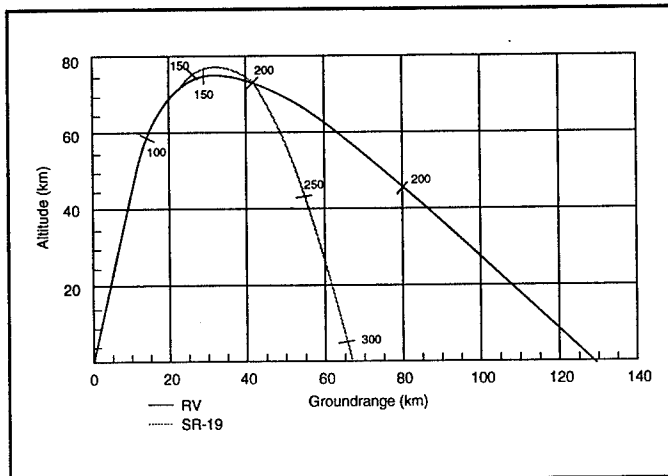

Figure 23: LC-32 Pile Driver Trajectory for HERA

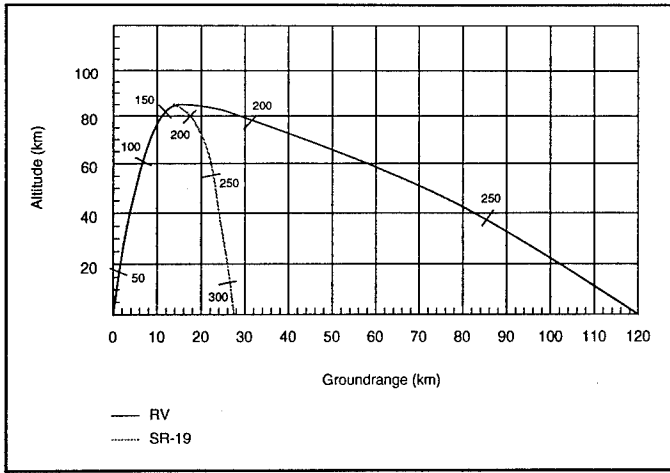

Figure 24: FIX Pile Driver Trajectory for HERA

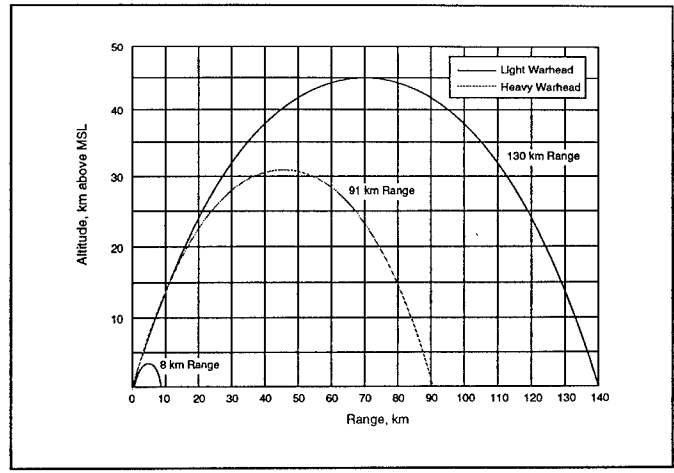

Figure 27: Lance Altitude vs. Range

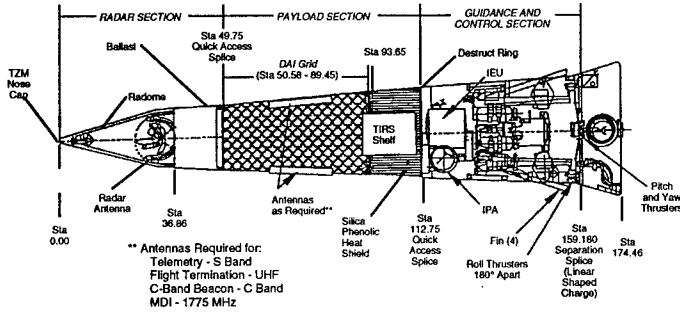

Figure 25: HERA MTV

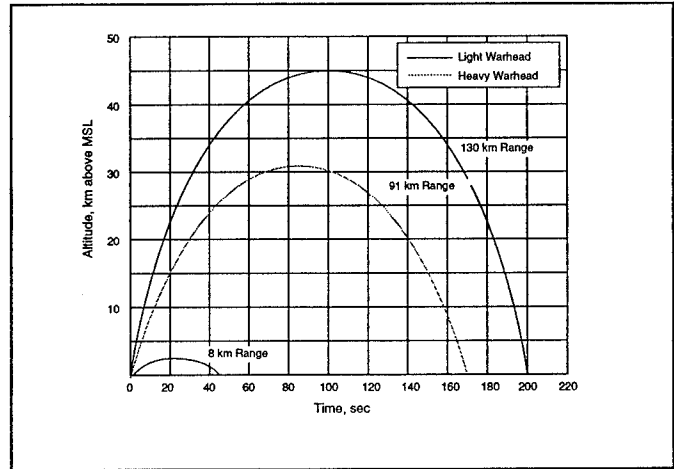

Figure 28: Lance Altitude vs. Time

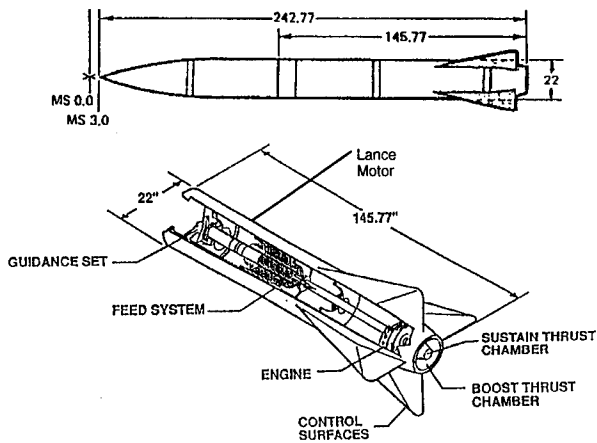

Figure 26: Lance Target System

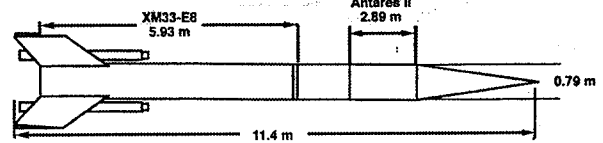

Figure 29: Strypi IX

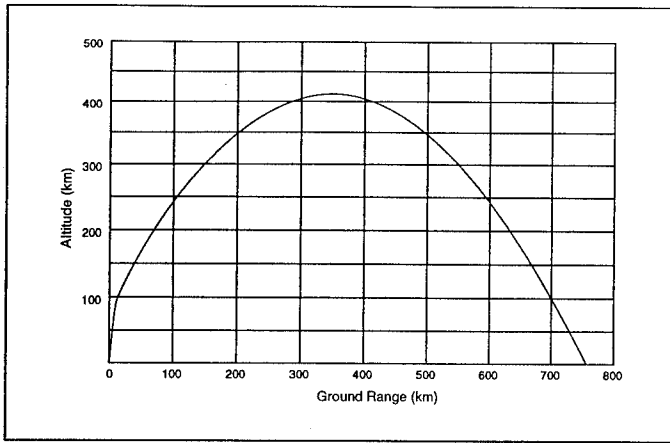

Figure 30: Strypi IX Altitude vs. Range

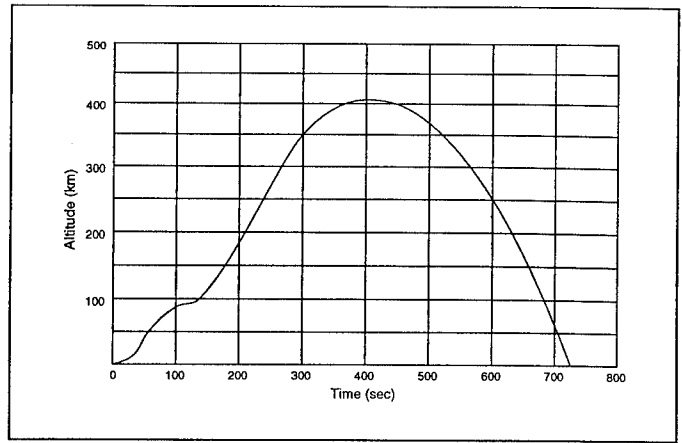

Figure 31: Strypi IX Altitude vs. Time