

Obtained Under the  
Freedom of Information Act  
by Hans M. Kristensen

# **MINUTEMAN WEAPON SYSTEM HISTORY AND DESCRIPTION**

**JULY 2001**

**Prepared For:  
INTERCONTINENTAL BALLISTIC MISSILE (ICBM)  
SYSTEM PROGRAM OFFICE (SPO)  
Hill AFB UTAH 84056  
OGDEN AIR LOGISTICS CENTER OO-ALC/LME**

**By: ICBM Prime Team  
TRW Systems  
Prime - 19378**





## ***FOREWORD***

This reference document provides general familiarization with the Minuteman Weapon System and its history. It discusses the various configurations of Minuteman facilities and the airborne vehicle equipment. It is intended to supplement the program tabulations in the ICBM Master Plan and aid the reader to visualize the effect of the programs on the system hardware.

The ICBM Master Plan will be revised annually, but this document will only be reissued when there are significant changes in the configuration of the weapon system. This version updates the May 1996 edition and brings the history and description current through 30 July 2001.





# TABLE OF CONTENTS

Foreword .....	I
Table of Contents .....	II
<b>SECTION ONE - MINUTEMAN WEAPON SYSTEM - AN OVERVIEW .....</b>	<b>1</b>
- Introduction .....	1
- Minuteman Communications Network .....	3
- Squadron Command and Status Communications .....	5
-- Missile Alert Facility .....	7
-- Flight Sequence .....	9
- The Role of Minuteman in the Triad .....	11
- Minuteman Missile Evolution .....	13
-- Minuteman Upgrade and Modification .....	15
-- Minuteman Deployment and Modernization Roadmap .....	17
-- ICBM Long Range Planning .....	21
-- Minuteman Deployment and Modification Matrix .....	23
-- Minuteman Weapon System Configuration .....	25
<b>SECTION TWO - MINUTEMAN AEROSPACE VEHICLE EQUIPMENT .....</b>	<b>27</b>
- Minuteman I Major Features .....	29
- Minuteman II Major Features .....	31
- Minuteman III Major Features .....	33
- Missile Operation .....	35
- Flight Control and Propulsion Systems Flight Control Group .....	37
-- Flight Control Equipment .....	39
- Propulsion .....	41
-- Minuteman III Stage1 .....	41
-- Minuteman III Stage 2 .....	43
-- Minuteman III Stage 3 .....	45
-- Minuteman III Propulsion System Rocket Engine .....	47
- Guidance Systems .....	49
-- Minuteman III Gyro Stabilized Platform .....	51
-- Minuteman III Flight Computer .....	53
-- Minuteman III Guidance Set Control .....	55
-- Minuteman III P92 Amplifier .....	57
- Reentry Systems .....	59
-- Mark 12/12A Reentry Systems .....	61

SECTION THREE - MINUTEMAN OPERATIONAL GROUND EQUIPMENT.....	63
- Missile Alert Facility .....	65
-- Launch Control Support Building .....	67
-- Launch Control Equipment Building .....	69
-- Launch Control Center .....	71
- Launch Facility .....	73
-- Launcher Structure .....	75
-- Launcher Equipment Room .....	77
-- Launcher Support Building .....	79
-- Launcher Equipment Building .....	81
-- Launch Facility Security System .....	83
SECTION FOUR - MINUTEMAN ORDNANCE .....	85
- Interstage Ordnance .....	87
- Thrust Termination System Ordnance .....	89
- Reentry System Ordnance .....	91
- Operational Ground Equipment Ordnance .....	93
SECTION FIVE - CHRONOLOGY OF MINUTEMAN DEVELOPMENT AND DEPLOYMENT .....	95
- Chronology 1956 - 1965 .....	96
- Chronology 1966 - 1974 .....	97
- Chronology 1975 - 1980 .....	98
- Chronology 1981 - 1989 .....	99
- Chronology 1991 - 2001 .....	100
ACRONYM LIST .....	101



## SECTION ONE

# ***MINUTEMAN WEAPON SYSTEM***

## ***-AN OVERVIEW-***

### ***INTRODUCTION***

The Minuteman Weapon System was conceived in the late 1950s, and developed and deployed in the 1960s. The system was designed to deter any aggressor, but if deterrence failed, to be able to withstand an attack and provide instant retaliation capability. At the time of its conception, Minuteman represented a new dimension in weaponry. Widely dispersing missiles in nuclear-hardened launchers was a novel idea that was developed into the present Minuteman Weapon System by the Ballistic Missile Organization of the Air Force Systems Command (AFSC). Today, engineering and maintenance of Minuteman is managed by the Intercontinental Ballistic Missile (ICBM) System Program Office (SPO) at the Ogden Air Logistics Center (OO-ALC) under Air Force Materiel Command (AFMC).

The figure below shows the location and configuration of the three current Missile Support Bases and the distribution of the Minuteman III missiles at those locations. Wings II, IV, and VI, located at Ellsworth, Whiteman, and Grand Forks AFBs, were deactivated with the retirement of Minuteman II and as a result of the base closure and realignment actions. The Minuteman III missiles from Wing VI were transferred to the former Minuteman II sites at Malmstrom AFB by the end of FY98. The darkened areas represent the location of the missile squadrons at each base. Each missile squadron consists of five flights; each flight consists of one Missile Alert Facility (MAF) and ten Launch Facilities (LFs).

# MINUTEMAN WEAPON SYSTEM DEPLOYMENT

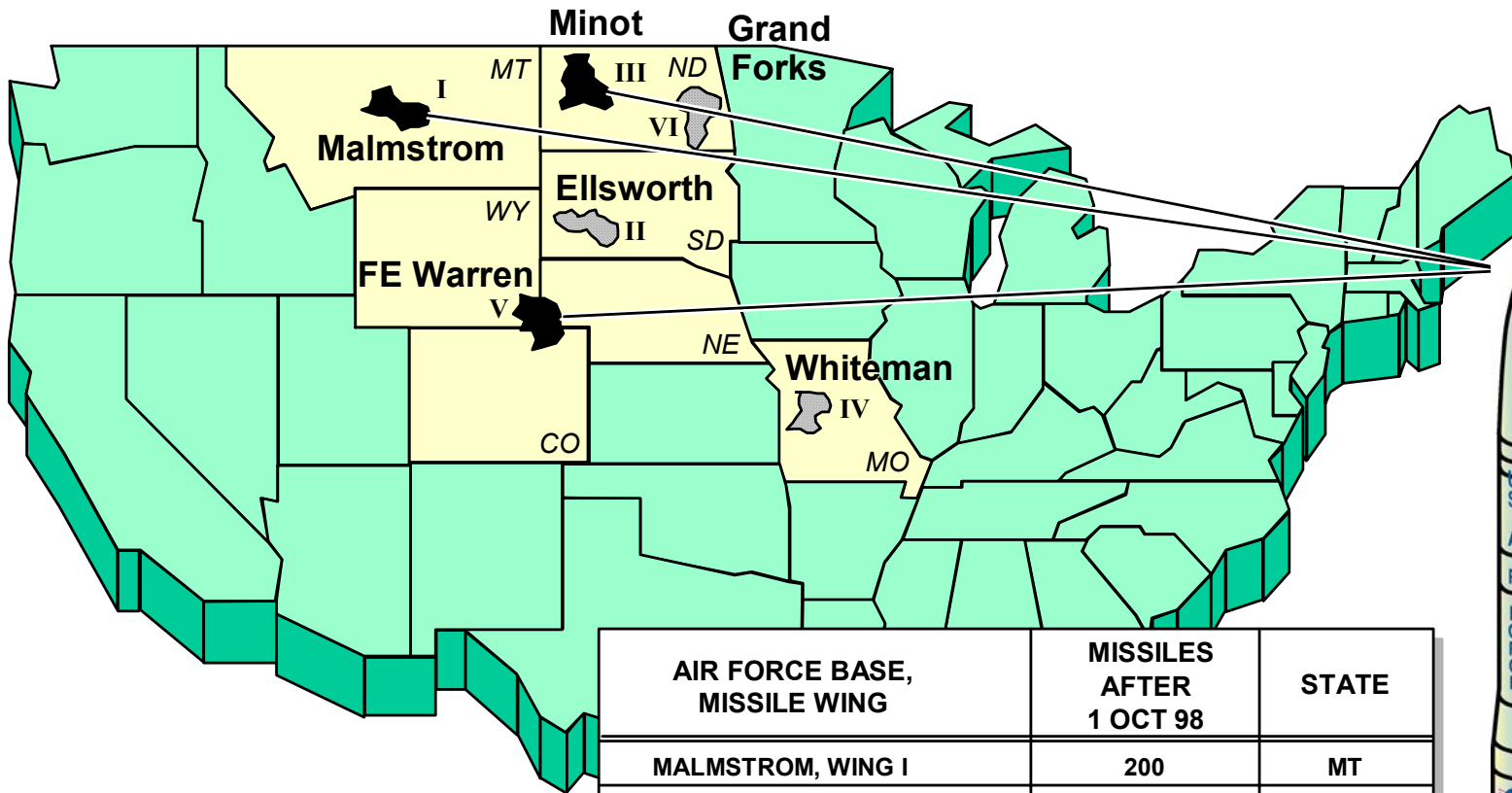

AIR FORCE BASE, MISSILE WING	MISSILES AFTER 1 OCT 98	STATE
MALMSTROM, WING I	200	MT
MINOT, WING III	150	ND
F. E. WARREN, WING V	150	WY, CO, NE
FORCE TOTAL	500	

(WINGS II, IV, AND VI DEACTIVATED)

MM III





# ***MINUTEMAN COMMUNICATIONS NETWORK***

If an act of aggression occurs and the president authorizes retaliation with the ICBM Force, US Strategic Command (USSTRATCOM) will immediately issue instructions through critical communications systems to selected USSTRATCOM Command Posts (CPs) to launch missiles against specified targets. In turn, each CP will pass a coded message via its communications system to one or more of the Launch Control Centers (LCCs) under its jurisdiction.

The Minuteman Weapon System employs multiple communications systems that provide links from the National Command Authority through USSTRATCOM and directly to the missile LCCs. There are two major communications system groups; Higher Authority Communications and Minuteman Command and Control Systems.

The Higher Authority Communications Network consists of complementary communication systems between higher authority and all LCCs. This network of diverse communications links provides the survivable command capability vital to overall weapon system effectiveness. The digital communication systems interface with the Rapid Execution and Combat Targeting (REACT) Higher Authority Communications/Rapid Message Processing Element (HAC/RMPE) for message receipt, processing, generation, and transmission. Commands and alert exercises are normally transmitted via the Strategic Automated Command and Control System (SACCS) which uses the commercial telephone and land-line network. The Ultra High Frequency (UHF), Air Force Satellite Communication System (AFSATCOM), Military Strategic Tactical and Relay (MILSTAR) UHF, ICBM Super High Frequency Satellite Terminal (ISST), and Survivable Low Frequency Communication System (SLFCS) radio systems provide assurance that higher authority communications will be maintained even if land-line service is lost. SLFCS and AFSATCOM will eventually be replaced by the Minuteman MEECN Program (MMP) which will install survivable MILSTAR EHF capability to the LCCs. The communications systems are exercised regularly to ensure readiness.

The Minuteman Command and Control System is the final command link from the LCCs to the missile LFs. This network consists of squadron wide, hardened, command/control, and status monitoring systems. The system provides the capability for any LCC to control all LFs in the squadron. The various command and control system functions include secure command and control communications, squadron-wide monitoring, missile launch, operational testing, and remote targeting. Squadron wide command and control is accomplished by message transmission over the hardened intersite cable system (HICS). The HICS is a hardened buried cable network providing communication paths between LCCs and LFs. At wing I Squadron 20, the Medium Frequency (MF) radio system complements the HICS in providing intra-squadron command and control system interconnectivity.

# MINUTEMAN COMMUNICATIONS NETWORK

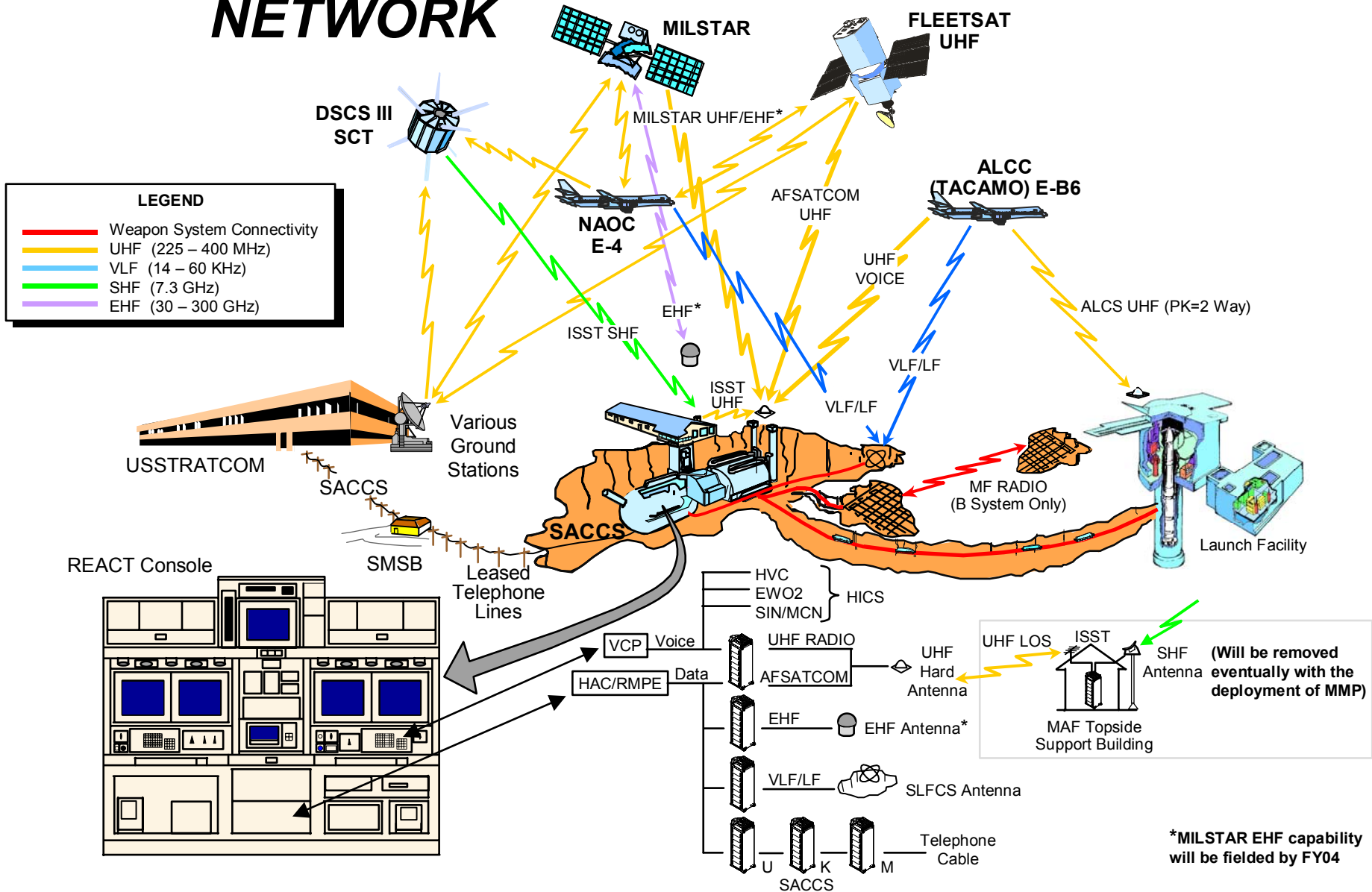





# ***SQUADRON COMMAND AND STATUS COMMUNICATIONS***

The squadron Command and Status Communications System consists of the hardened intersite cable system and the MF radio systems that connect MAFs and LFs. The cable systems are buried to help provide protection from nuclear effects. The WS-133A-M system uses redundant cable paths in a wagonwheel-spoke configuration with the MAF at the center and four radial cable runs out to the ring trunk. Inter-flight connectivity is also provided by buried cable.

The WS-133B system located at Wing I Squadron 20 uses a single backbone cable with cable runs stubbed off to the LFs. The B system has an MF radio overlay to the the cable system to provide the command and status messaging redundancy between LFs and LCCs as well as between flights.

Each MAF has primary control and responsibility for the 10 LFs within its flight. A squadron is comprised of five flights. Each of the five MAFs also has the ability to command and monitor all 50 LFs within the squadron.

# SQUADRON COMMAND AND STATUS COMMUNICATIONS

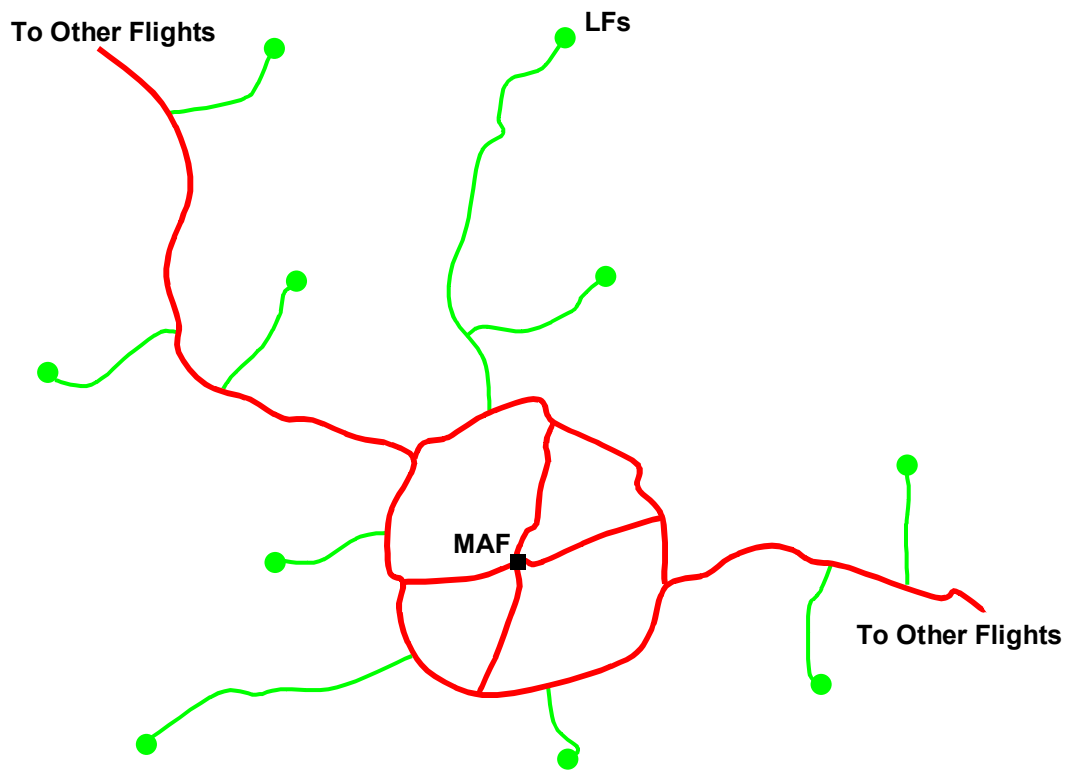

A-M System Flight Configuration

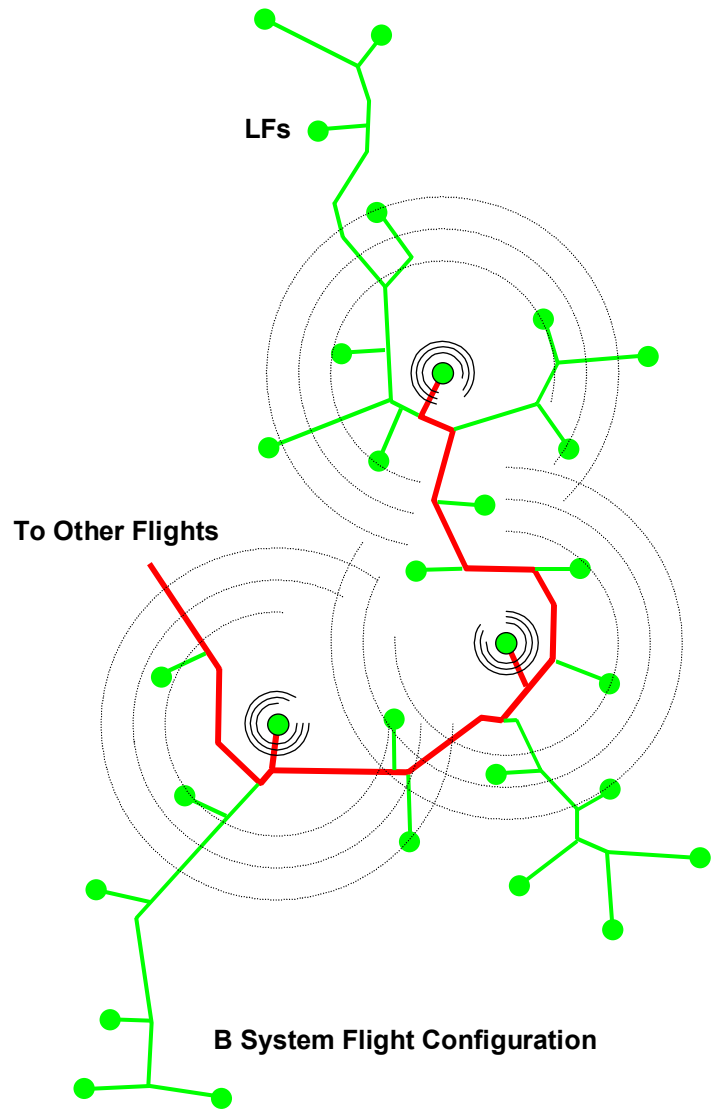

B System Flight Configuration

# **MISSILE ALERT FACILITY**

MAFs are located at each operational missile wing for command, control, and monitoring of the Minuteman LFs. The MAF consists of a buried and hardened LCC, an above-ground Launch Control Support Building (LCSB) at Wing I, and at Wings III, V, and I/Squadron 20, a buried and hardened Launch Control Equipment Building (LCEB) to house the cooling and generator systems. The command and control equipment is located in the LCC. Each LCC has primary control and responsibility for the 10 LFs within its flight. A squadron is comprised of five flights. Each of the five LCCs also has the ability to command and monitor all 50 LFs within the squadron.

When a valid emergency action message (EAM) directing launch is received at the LCC, the two Missile Combat Crew Members (MCCMs) take the required actions to configure the missiles for launch. This includes sending the enable codes to the missiles and transmitting the proper preparatory launch command (PLC). The PLC contains all information to execute the designated war plan. The officers then simultaneously turn launch switches in physically separated panels on the REACT console to start the automatic launch sequence. This begins a precisely sequenced series of automatic operations: 1) a final check of the system for combat readiness is made; 2) the launcher closure door is removed; 3) the upper umbilical is retracted from the missile; and 4) the first stage rocket motor is ignited.

The entire launch sequence takes less than 60 seconds. Normally, two LCCs are required to “vote” to execute a launch. A single vote capability and the Airborne Launch Control Center (ALCC) provide back-up capability.

# MISSILE ALERT FACILITIES

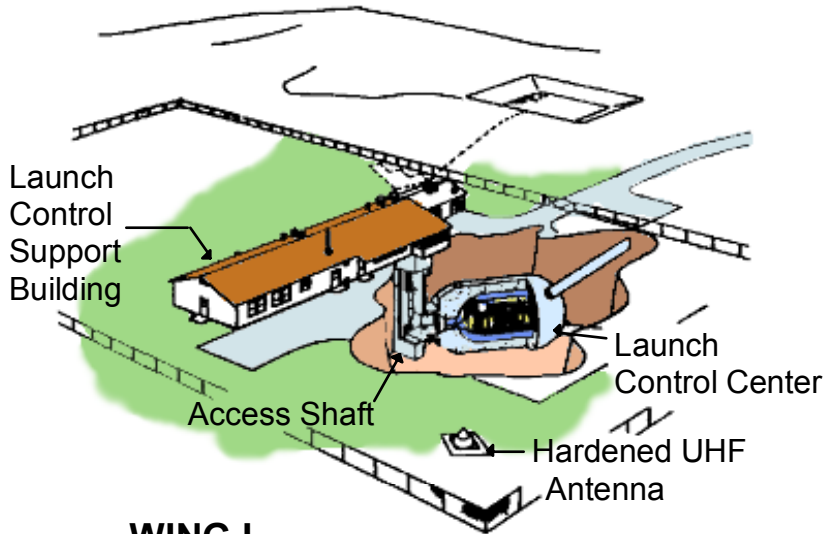

**WING I  
(WS-133A-M)**

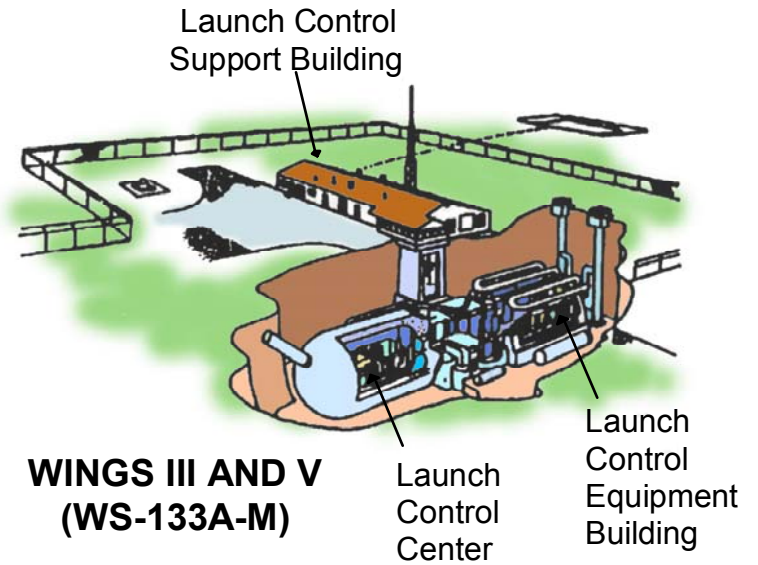

**WINGS III AND V  
(WS-133A-M)**

**WING I  
SQUADRON 20  
(WS-133B)**

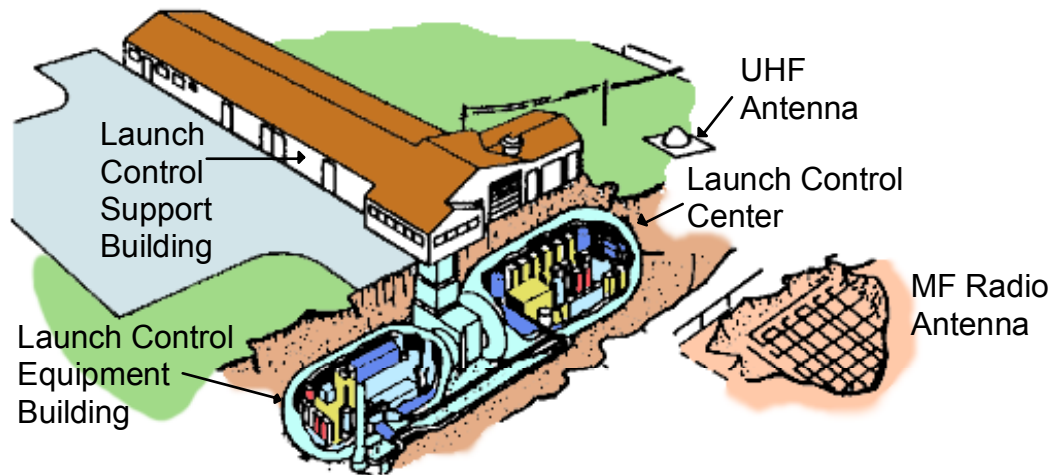



# ***FLIGHT SEQUENCE***

During the flight, the Missile Guidance Set (MGS) computer sends commands to control inflight operations and keep the missile on the precise course required to deliver the reentry vehicles (RVs) to their designated targets. During Stage 1 flight, the MGS controls missile direction by manipulating the Stage 1 nozzles. At the proper instant, the computer commands first-stage separation and second-stage ignition. Then MGS steering commands are sent to the second-stage thrust vector control (TVC) unit to keep the rocket on course. Second-stage separation and third-stage ignition occur at the appointed time and the MGS continues its task of navigating according to the program stored in the computer.

When the computer senses the missile has reached the correct point in its flight path, thrust termination (TT) ports in the front of the third-stage motor are opened for negative thrust. The post-boost vehicle (PBV) separates from the third stage motor and is maneuvered by the MGS to the pre-determined points of RV deployment. The RVs are then pre-armed and separated one at a time from the post-boost system. The RVs follow individual ballistic trajectories, reenter the earth's atmosphere, arm, and detonate according to the planned target profile.

# FLIGHT SEQUENCE

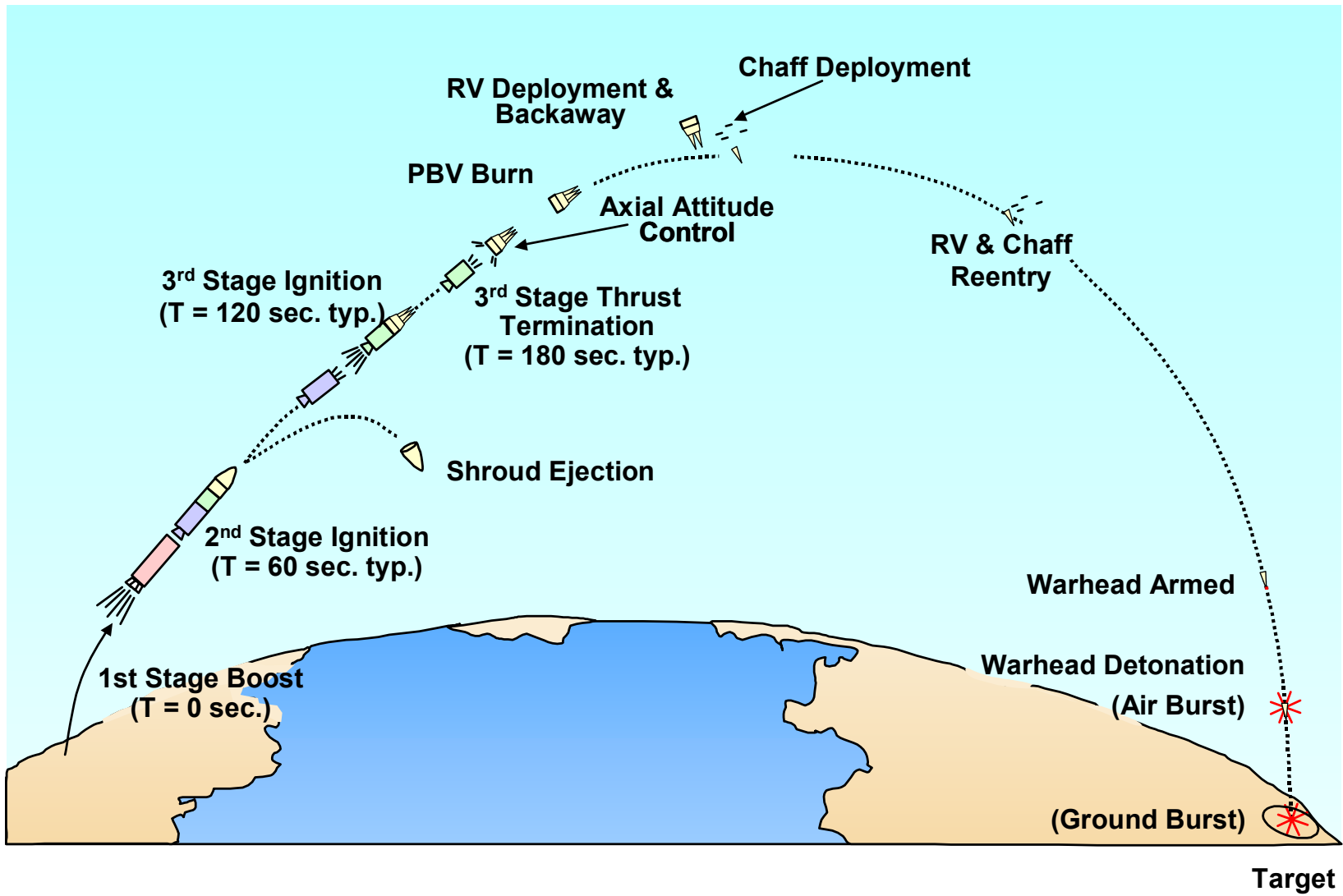



# ***THE ROLE OF MINUTEMAN IN THE TRIAD***

Land-based ICBMs provide one of the three elements of the nation's strategic force, the "Triad." The Triad consists of the Air Force bomber fleet, the land-based ballistic missile fleet, and the Navy's sea-launched ballistic missile fleet.

Each element complements the other two. For example, each element depends on a different mode for prelaunch survival: the land-based missiles, upon dispersion and hardness; the sea-launched missiles, upon uncertainty of location; and the bomber force, upon tactical warning coupled with quick reaction. The diversified concept of the Triad provides a reasonable assurance of depriving an enemy of the ability to "knock out" more than one of the elements in a surprise attack. This complicates economically, as well as physically, an aggressor's own defense problem.

The figure below lists 17 characteristics which the Department of Defense (DoD) determined to be essential in an ideal weapon system and shows that no single element of the Triad meets all of the requirements. In combination, however, one or more of the elements cover each of the 17. The vital role of the land-based ICBMs in this concept is evident.



# THE ROLE OF MINUTEMAN IN THE TRIAD

	Bombers: B-52s, B-2s	Land-Based ICBM Systems: (Minuteman, Peacekeeper)	Sea Based Missile System: (Trident I, Trident II)
Range	■	■	■
Payload	■	■	■
Accuracy	■	■	■
Penetration		■	■
Flexibility	■	■	■
Communications	■	■	
Reliability	■	■	
Security	■	■	
Recall	■		
Availability		■	
Survivability		■	■
Post Attack Life		■	■
Assessment	■		
Reaction Time		■	■
Collateral Damage		■	■
Arms Control	■	■	■
Crisis Management	■		





# ***MINUTEMAN MISSILE EVOLUTION***

The first generation of Minuteman, the Minuteman I (LGM-30A and B), was a highly reliable, three-stage, solid-propellant missile, capable of withstanding storage in an alert “ready” condition for long periods of time. Minuteman I ground systems were designated WS-133A, and missiles were installed in underground launchers located at unmanned sites. Each missile was capable of being launched, even after being subjected to overpressure from a nuclear blast, with a range of over 5,000 nautical miles and a continuously operating guidance set.

The basic characteristics of the WS-133 weapon system have not changed since Minuteman I missiles were deployed. However, advances in technology and changes in national policy induced improvements in the original design. The 800 Minuteman I missiles which stood guard over 20 years ago were replaced by the more capable Minuteman II (LGM-30F) and later, by the Minuteman III (LGM-30G) missiles, shown below. The ground systems, which house and support the missiles, have also been made more survivable, efficient, and secure over the years. In June 1992, the Air Force began retiring Minuteman II so that the LGM-30G missile was the only version of Minuteman fielded by 1995.



# MINUTEMAN MISSILE EVOLUTION

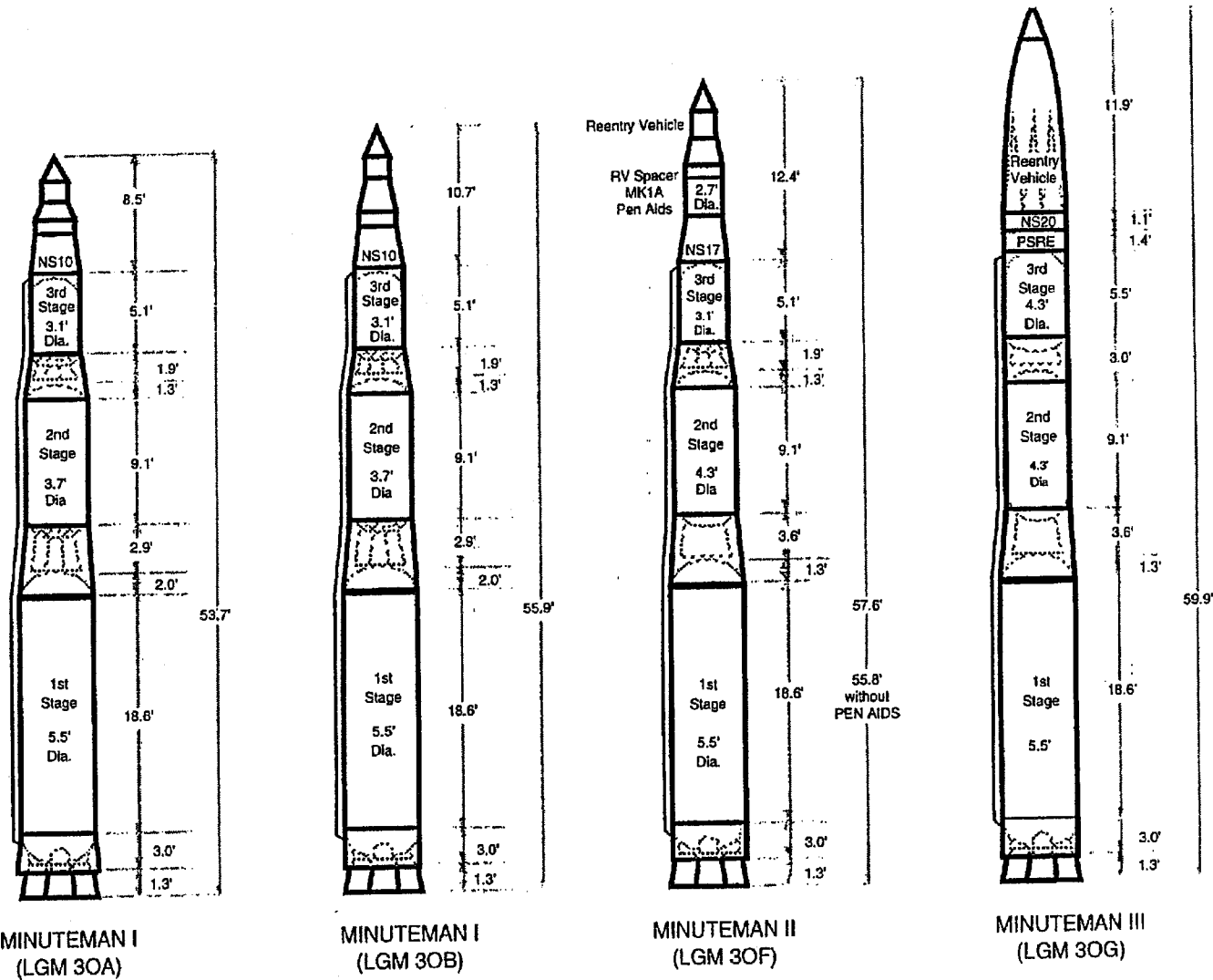



# ***MINUTEMAN UPGRADE AND MODIFICATION***

By 1964 major improvements had been made to the original ground system and missile design, and Wing VI was built with these improvements to accommodate the Minuteman II missile. This ground system was designated WS-133B. After Wing VI deployment, the same new ground system was used to add one squadron of Minuteman II missiles to Wing I. This is Squadron 4 of Wing I, but has been referred to as the “Colocated squadron” or “Squadron 20,” as it was the 20th Minuteman squadron deployed in the force.

After the WS-133B ground system was built, the WS-133A ground system at Wings I and III through V was modified to incorporate characteristics similar to those of the WS-133B system in order to accommodate either Minuteman II or Minuteman III missiles. This included the installation of the Command Data Buffer (CDB) at all wings except Wing II to provide remote retargeting capability and other upgrades. Also, new requirements were established to increase the system’s “nuclear hardness.” Nuclear hardness is a term representing how resistant a system is to nuclear effects. Initially, the hardness was upgraded to a limited extent at Wing II. Later, a more extensive hardness upgrade was performed at the remaining wings beginning with Wing V. The changes were implemented as part of the Force Modification and Silo Upgrade Programs. After a WS-133A wing was modified, it was given the new designation WS-133A-M.

The concrete-walled subsurface Launcher Support Building (LSB) at Wings I - V was originally constructed with only a limited degree of nuclear hardness. The Launcher Equipment Building (LEB) at Wing VI and Squadron 20 was encapsulated and buried underground to increase nuclear hardness. Direct attack hardness requirements for both the LSB and LEB were deleted in the 1980s, leaving only electromagnetic pulse (EMP) requirements for these facilities.

Part of the equipment in the LCSB at Wings I and II (the standby electric power and the environmental control for the building and for the LCC capsule) was moved underground at Wings III, IV, and V and was encapsulated at Wing VI and Squadron 20. (See the Minuteman Deployment and Modification Matrix at the end of this section.)



# ***MINUTEMAN DEPLOYMENT AND MODERNIZATION ROADMAP (Cont'd)***

An integrated improvement program was started in the early 1970s. This program incorporated the following improvements: EMP hardening, silo upgrade to improve hardness, the Command Data Buffer for remote programming of the guidance system, and dust hardening of the MM III Propulsion System Rocket Engine (PSRE) by installing covers over the attitude control motors.

Other significant milestones in the Minuteman system deployment were the Rivet SAVE program which allowed a one-third reduction in the crew force; the Stage 2 Washout and Stage 3 replacement of aged-out booster motors; the Accuracy, Reliability, and Supportability Improvement Program (ARSIP) for the MM II NS-17 MGS; the partial replacement of LF batteries with high-life lithium storage batteries for extended survivable power; and the Rivet Minuteman Integrated Life Extension (MILE) depot level maintenance program.

By 1987, the Minuteman force configuration stood at 450 Minuteman IIs and 500 Minuteman IIIs after the deployment of 50 Peacekeeper missiles in Minuteman Silos (PIMS) was completed in 1986. The decision to begin retiring the Minuteman II system in 1992 resulted in the deactivation of Wing II based at Ellsworth AFB, Rapid City, SD and Wing IV based at Whiteman AFB, MO. At the same time, 30 Minuteman III missiles were taken from storage and placed in the A-M system in Wing I as part of the Rivet ADD program. This brought the total of Minuteman III missiles deployed to 530, as well as the 50 Peacekeeper missiles deployed in Wing V, by the end of 1995. The Base Realignment and Closure (BRAC) decision in 1995 to close Wing VI at Grand Forks AFB, ND, was accommodated by moving 120 Minuteman III missiles to Wing I, bringing the eventual total MM III missiles deployed to 500 by the end of FY98.

# MINUTEMAN DEPLOYMENT AND MODERNIZATION ROADMAP (Cont'd)

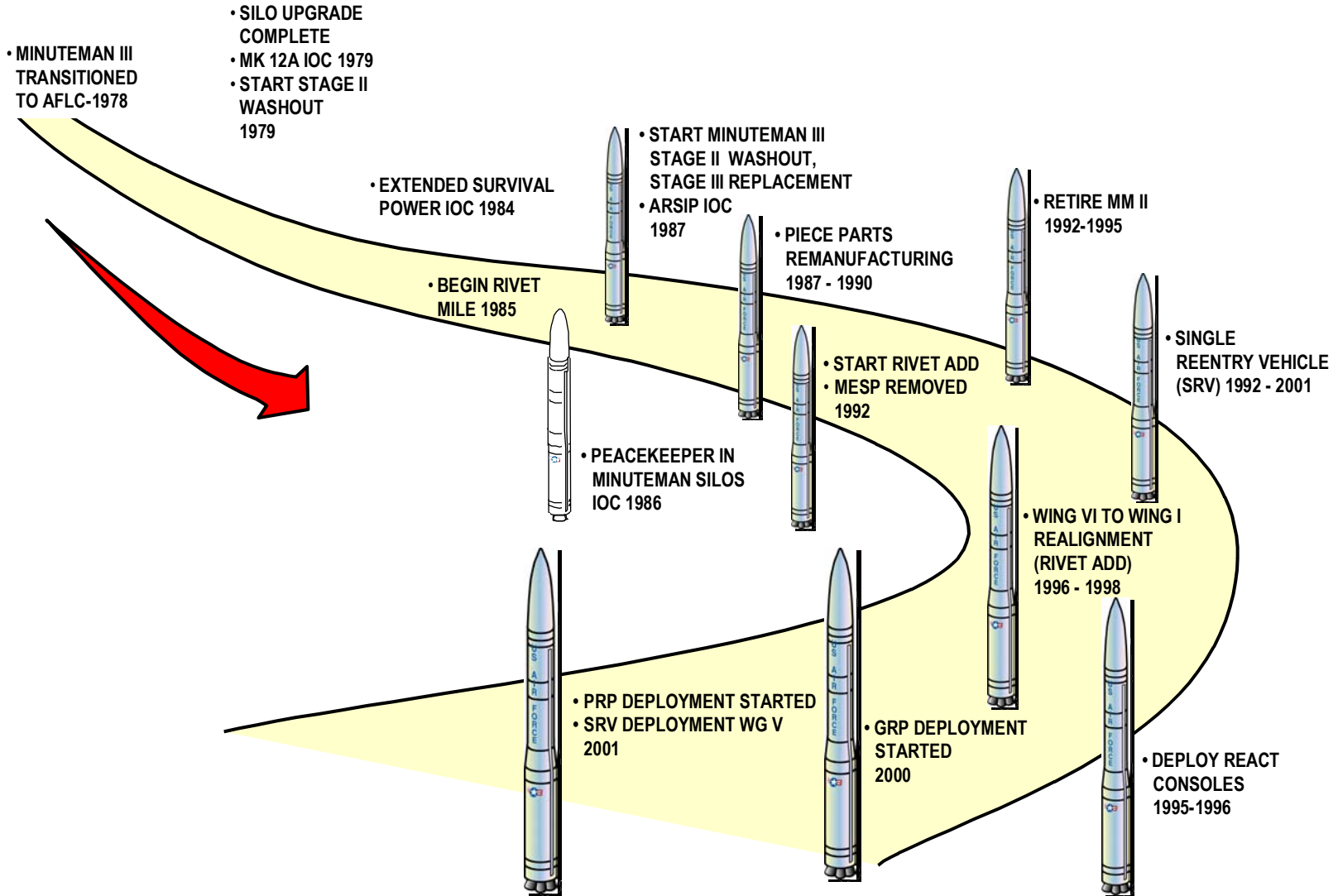



# ***ICBM LONG-RANGE REQUIREMENTS PLANNING***

The objective of the ICBM Long-range Requirements Planning (ILRP) Program is to identify the requirements and programs needed to sustain ICBM performance and support, meet evolving mission requirements, and provide the justification for program advocacy in the budget cycle. The ILRP organization consists of a working group and steering group headed by an executive level committee. The ILRP Working and Steering Groups, which include representatives from HQ AFSPC, ICBM SPO, HQ USAF, 20AF, USSTRATCOM, SAF, and other agencies address mission objectives, logistics support requirements, and system options. The using command, HQ AFSPC, defines performance shortfalls and/or needed system enhancements while the ICBM SPO determines the acquisition approach and associated schedule and cost estimates for the ICBM Master Plan (formerly called the Twenty-year Technical Plan).

The first Twenty-Year Technical Plan was initiated in 1985. It used existing Program Objective Memorandum (POM) year programs as a starting point, defined orderly and cost-effective future system requirements, and structured programs to accomplish coordinated system improvements to extend the Minuteman II and III life cycles. Due to advancing age, numerous components in the missile and operational ground equipment (OGE) were becoming logistically unsupportable. Major extended life and mission enhancement programs were directed to meet projected long range needs, as shown in the roadmap below.



# MINUTEMAN ROADMAP - WHERE WE ARE GOING

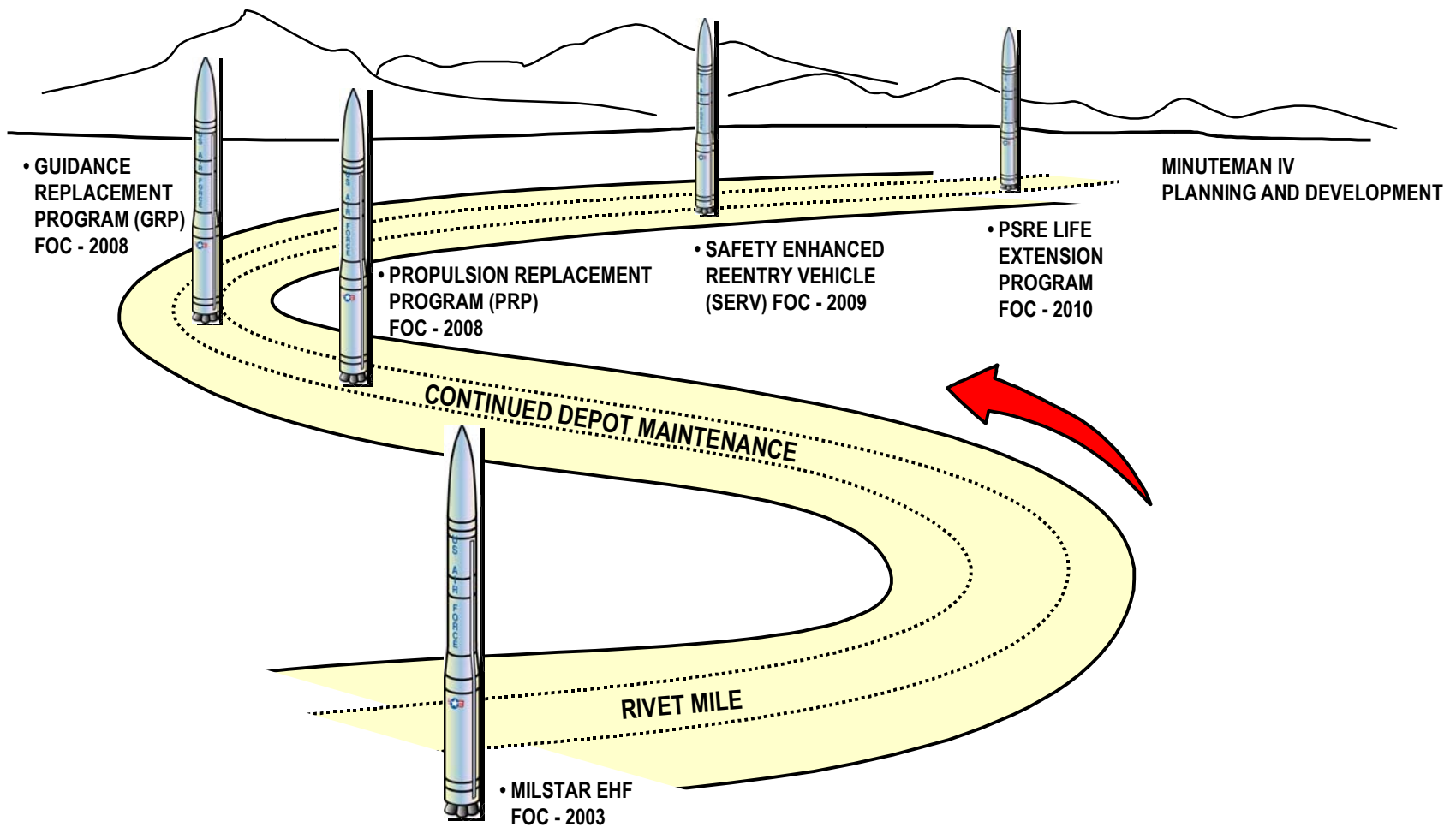



# ***MINUTEMAN DEPLOYMENT AND MODERNIZATION MATRIX***

The following table shows the initial deployment dates for the Minuteman I system (WS-133A) and Minuteman II system (WS-133B) along with subsequent modernization and modification completion dates. For a detailed review of the Minuteman Weapon System refer to the following Minuteman Aerospace Vehicle, OGE, Ordnance and Chronology sections.





# MINUTEMAN DEPLOYMENT AND MODIFICATION MATRIX

MODIFICATION	WING I MALMSTROM AFB	WING II ELLSWORTH AFB	WING III MINOT AFB	WING IV WHITEMAN AFB	WING V F. E. WARREN AFB	WING VI GRAND FORKS AFB	WING I SQUADRON 20 MALMSTROM AFB
WS-133A System Deployment	1963	1963	1964	1964	1965	----	----
WS 133B System Deployment	----	----	----	----	----	1966	1967
Minuteman I Operational	1963	1963	1964	1964	1965	----	----
Minuteman II Operational	1969	1973	----	1967	----	1966	1967
Force Modernization WS-133A-M	1969	1973	1971	1967	1975	----	----
Minuteman III Operational	----	----	1971	----	1975	1973	1975
Silo Upgrade	1979	1973*	1976	1980	1975	1977	1977
Hardness Modification	1979	1973	1976	----	----	1977	1977
Command Data Buffer	----	----	1976	----	1975	1977	1977
Improved Launch Control System	1979	----	----	1980	----	----	----
REACT	1996	----	1996	----	1995	----	1996
MM II Deactivation	1995	1994	----	1995	----	----	----
Rivet ADD	1998	----	----	----	----	1998	----

\* Partial silo upgrade.

Note: Dates reflect completion





# **MINUTEMAN WEAPON SYSTEM CONFIGURATIONS**

This table contains the current weapon system configurations at each of the missile wings.

The first two columns list the common wing numbers of each of the wings and the number of missile sites they include. The third column title “Weapon System” names the configuration of the MAFs and LFs for each wing.

Under the title “Missiles,” the fourth, fifth and sixth columns indicate the type of missile, MGS, and RV equipment used at each wing.

The next two columns under “Facilities” list the type of facilities at each wing and degrees of designated hardness.

The “Software” column lists the type of ground/flight targeting software used at each wing.

The following list of acronyms will aid in understanding the table:

CDB	Command Data Buffer
EEP	Expanded Execution Plan
GUP	Guidance Upgrade Program
LCEB	Launch Control Equipment Building
LCC	Launch Control Center
LCSB	Launch Control Support Building
LEB	Launcher Equipment Building
LSB	Launcher Support Building
LF	Launch Facility
S	Soft
H	Hard
VH	Very Hard

Wings II and IV, located respectively at Ellsworth AFB, SD, and Whiteman AFB, MO, were deactivated with the removal of the Minuteman II missiles and MK 11C RVs. Both wings contained 150 LFs in the WS-133A-M configuration. Up until 1992, a portion of the 150 Minuteman II missiles at Wing IV carried the Emergency Rocket Communications System (ERCS) payloads in place of the normal MK 11 RVs.



# MINUTEMAN WEAPON SYSTEM CONFIGURATIONS

WING		WEAPON SYSTEM	MISSILES			FACILITIES		SOFTWARE
NUMBER	SITES	NAME	TYPE	G&C (NS-)	RV (MK-)	TYPE	GROUND ATTACK HARDNESS *	GROUND FLIGHT TARGETING
I	150	WS-133A-M	III	20/50	12/12A	LF LSB LCC LCSB	VH S VH S	EEP/CDB
SQD 20	50	WS-133B	III	20/50	12	LF LEB LCC LCEB	VH S VH VH	EEP/CDB
III	150	WS-133A-M	III	20/50	12A	LF LSB LCC LCEB	VH S VH H	EEP/CDB
V	150	WS-133A-M	III	20/50	12	LF LSB LCC LCEB	VH S VH H	EEP/CDB

\* All facilities listed are hardened for high altitude burst EMP

Updated 4/01

# ***MINUTEMAN AEROSPACE VEHICLE EQUIPMENT***

This section provides an overview of major features of each Minuteman missile configuration and discusses Minuteman flight control, propulsion, missile guidance and reentry systems. The table below provides some mass properties data for Minuteman I, Minuteman II, and Minuteman III. The charts which follow detail information concerning each stage of Minuteman II and Minuteman III missiles, and describe the missile guidance, flight control, and reentry systems.



# MISSILE MOTOR SPECIFICATIONS

CATEGORY	MINUTEMAN I			MINUTEMAN II			MINUTEMAN III *		
	STAGES			STAGES			STAGES		
	1	2	3	1	2	3	1	2	3
TOTAL WEIGHT (lbs)	51,251	12,072	4,484	51,230	16,057	4,443	51,230	16,039	8,197
PROPELLANT WEIGHT (lbs)	45,670	10,380	3,668	45,670	13,680	3,668	45,670	13,680	7,292
LENGTH (ft)	18.6	9.1	5.1	18.6	9.1	5.1	18.6	9.1	5.5
DIAMETER (ft)	5.5	3.7	3.1	5.5	4.3	3.1	5.5	4.3	4.3
THRUST (lbs)	200,400	45,600	17,100	200,400	60,700	17,100	200,400	60,700	34,500
MOTOR CASE MATERIAL	D6AC Steel	Titanium	S-901 Fiberglass	D6AC Steel	6AL-4V Titanium	S-901 Fiberglass	D6AC Steel	6AL-4V Titanium	S-901 Fiberglass
PROPELLANT MATERIAL	TP-H1011 TP-H1043	ANP-2862 ANP-2864	CYH & DDP	TP-H1011 TP-H1043	ANB-3066	CYH & DDP	TP-H1011 TP-H1043	ANB-3066	ANB-3066 TYPE 1
MANUFACTURERS	Thiokol	Aerojet	Hercules	Thiokol	Aerojet	Hercules	Thiokol	Aerojet	CSD

\* Current configuration stages. PRP booster first article delivery in April 01. Motor specifications and manufacturers will be updated in next revision.



# ***MINUTEMAN I MAJOR FEATURES***

Minuteman I was a highly reliable, three-stage, solid-propellant weapon, capable of withstanding storage in an alert ready condition for long periods of time. It had a range of well over 5,000 nautical miles and its inertial guidance system operated continuously. Advances in technology and changes in national policy induced improvements in the original design.

Physical changes in Minuteman I, II, and III missiles are the result of performance improvements that have taken place over the life of the weapon system.

# MINUTEMAN I MAJOR FEATURES

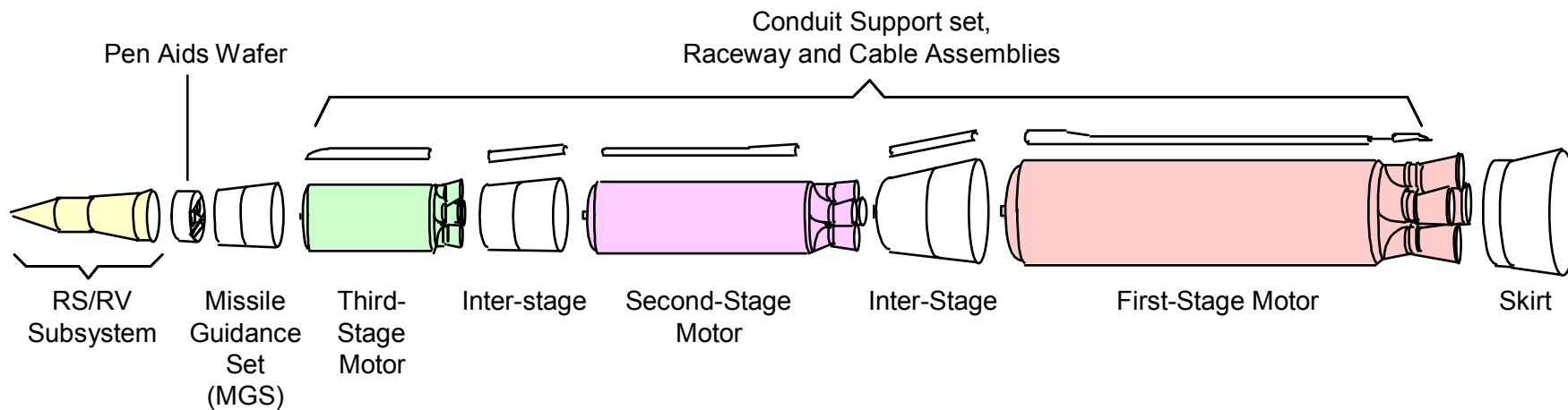



# *MINUTEMAN II MAJOR FEATURES*

Performance improvements realized in Minuteman II include greater range, increased throw weight, improved accuracy and reliability, multiple target selection, and greater penetration capability. The major new features provided by Minuteman II were:

- An improved first-stage motor to increase reliability.
- A new-technology, single, fixed nozzle with liquid injection thrust vector control (TVC) on a larger second-stage motor to increase missile range. Additional motor improvements to increase reliability.
- An improved guidance system, incorporating semiconductor integrated circuits and miniaturized discrete electronic parts. Minuteman II was the first program to make a major commitment to these new devices. Their use made possible multiple target selection, greater accuracy and reliability, a reduction in the overall size and weight of the guidance system, and an increase in the survivability of the guidance system in a nuclear environment.
- A penetration aids system to camouflage the warhead during its reentry into an enemy environment.
- A larger warhead in the reentry vehicle (RV) to increase kill probability.



# MINUTEMAN II MAJOR FEATURES

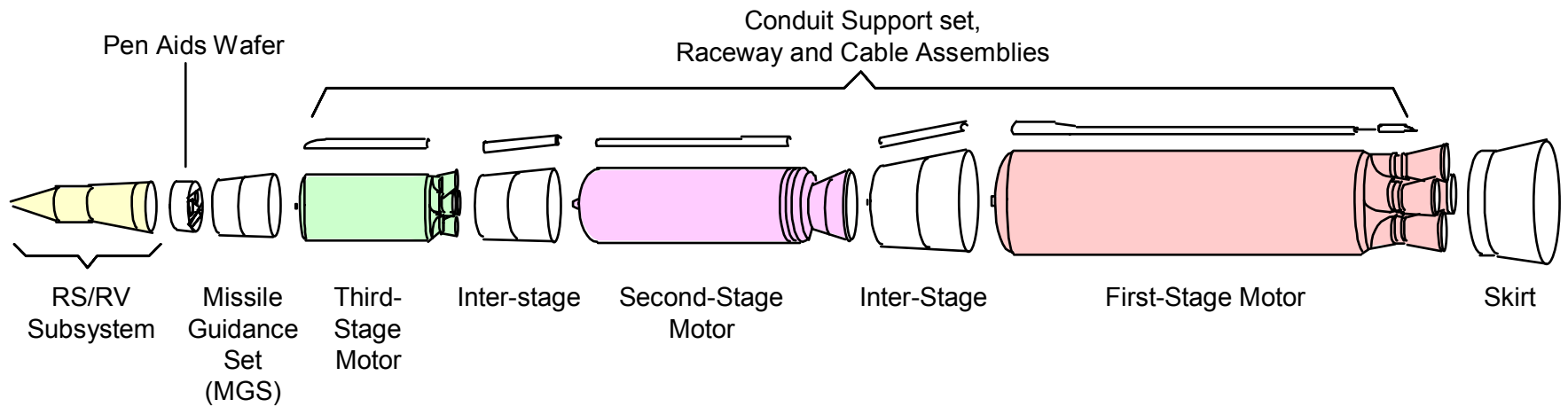



# ***MINUTEMAN III MAJOR FEATURES***

Performance improvements realized in Minuteman III include increased flexibility in reentry vehicle (RV) and penetration aids deployment, increased survivability after a nuclear attack, and increased payload capacity.

Minuteman III contains the following distinguishing features:

- A larger third-stage motor to increase range.
- A fixed nozzle with a liquid injection TVC system on the new third-stage motor (similar to the second-stage Minuteman II nozzle) to increase range.
- A RS capable of deploying penetration aids (chaff) and up to three RVs to increase payload delivery.
- An added post-boost propulsion system (the Propulsion System Rocket Engine, or PSRE) to increase range and maneuver the RS. This maneuverability allows the RS to be positioned at selected locations prior to the deployment of its RVs and penetration aids.
- Improved electronics in the guidance system to provide more computer memory and greater accuracy, and to reduce vulnerability to a nuclear environment.

# LGM 30G OPERATIONAL MISSILE

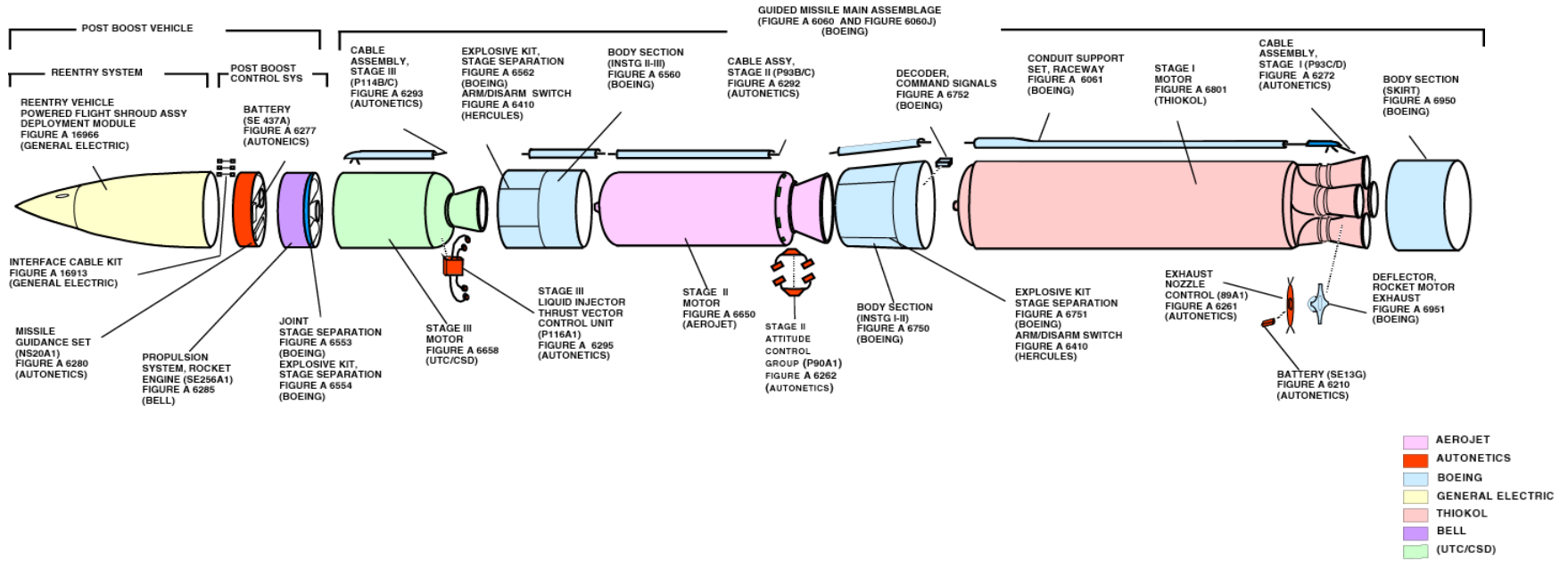



# ***FLIGHT CONTROL EQUIPMENT***

The table below lists the Flight Control Equipment (FCE) used on the first three stages of the Minuteman III missile. The figure is a sketch of a Stage 1 P89.

FCE on the Minuteman missile has changed with system evolution. There were FCE improvements with each major system upgrade, from Minuteman I to Minuteman II, but the functions remain the same in each system. These functions are: 1) Maintain stable control of missile attitude during the powered boost and post-boost portions of flight; 2) Execute stagings on command from the guidance system; and, 3) Perform velocity and deployment maneuvers on command from the guidance system.

The P89 unit controls four moveable exhaust nozzles, which in turn control orientation of the thrust vector, providing pitch, yaw, and RC. The P90 and P116 units control pintle valves which inject liquid into the nozzle exhaust stream, thus providing pitch and yaw control by deflecting the thrust vector. RC is accomplished by the ejection of hot exhaust gas through one of a pair of opposed nozzles perpendicular to the direction of the missile thrust vector.

# P89 NOZZLE CONTROL UNIT SECTIONAL VIEW

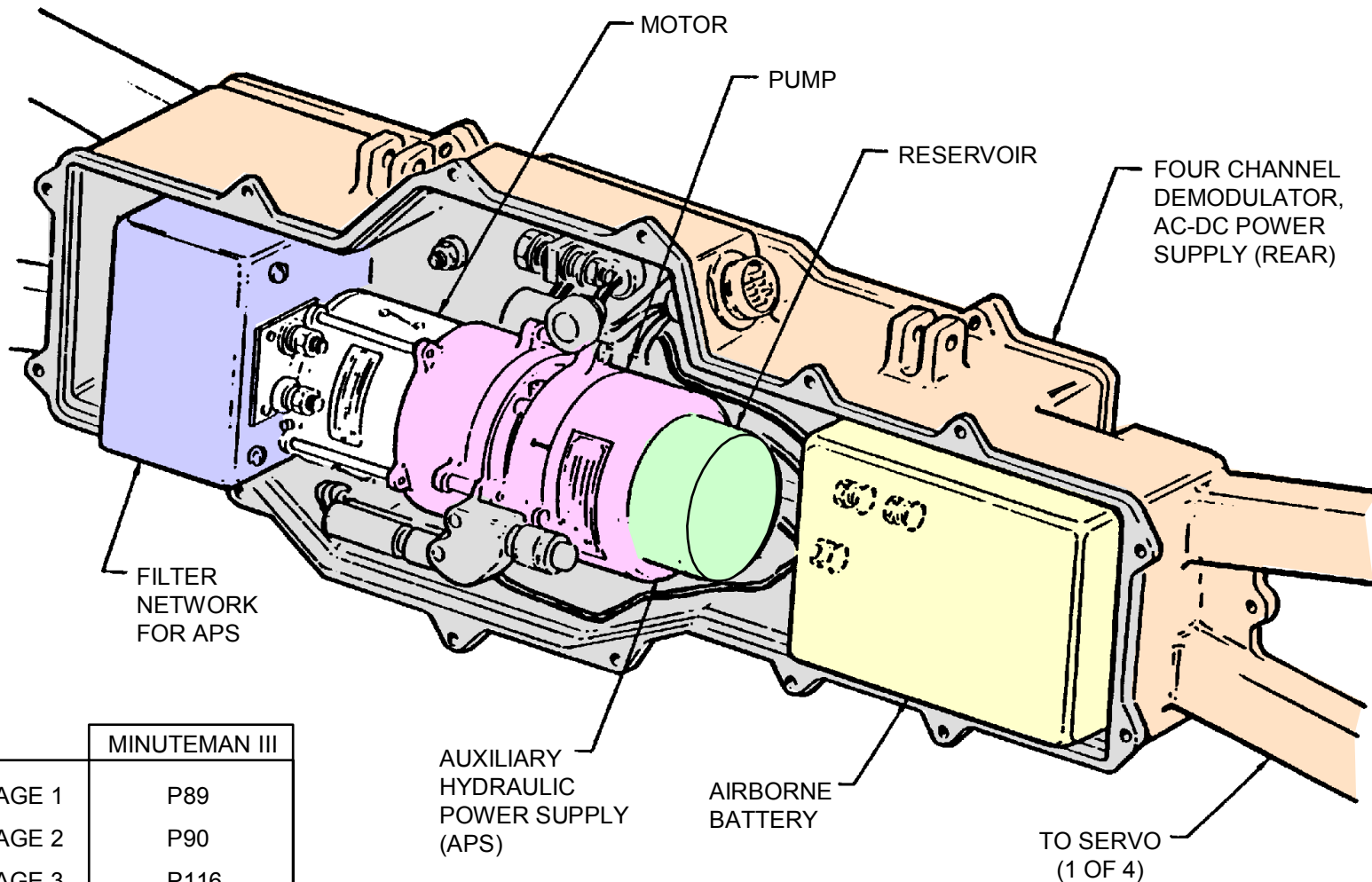

MINUTEMAN III	
STAGE 1	P89
STAGE 2	P90
STAGE 3	P116



# ***PROPULSION STAGE 1***

The first-stage motor (common to both Minuteman II and Minuteman III) consists of a steel motor case, a Class 1.3 solid propellant, an igniter, a steel aft closure with four moveable nozzles, and a Nozzle Control Unit (NCU) for TVC. Each nozzle is capable of pivoting through an angle of  $\pm 8$  degrees from null, in a plane parallel to the motor centerline and perpendicular to the pivot planes of the adjacent nozzles. The motor was designed and built by the Thiokol Corporation; the NCUs, which are part of the guidance system (Section Three), were designed and built by Rockwell International.

A single high-performance solid propellant is cast into the motor case with a six-point star hollow core, which maintains thrust by keeping a constant surface area as the propellant burns away. The propellant consists of an ammonium perchlorate oxidizer, aluminum powder fuel, a polybutadiene acrylic acid binder, and an epoxy-resin curing agent.

The case serves as the missile structure with the interstage attached at its forward end and the skirt at the aft end. The closure and nozzles are insulated from the thermal effects of the chamber temperature by molded plastic, Buna-N rubber, mastic insulation, and high-density graphite parts. A low-temperature ablative epoxy insulation (Avcoat) protects the motor case exterior from silo launch, nuclear thermal, and aerodynamic heating. This material will be changed to Vamac rubber with booster production under the Propulsion Replacement Program (PRP).

The nozzles, which move in response to commands issued by the guidance system to the NCUs, control the attitude of the missile during the first stage of flight. The pair of laterally opposed nozzles pivot up and down for pitch control. The vertically opposed pair pivot sideways for yaw control, and in opposition for roll control. All four nozzles are used to maintain roll stability.

# MINUTEMAN III STAGE 1

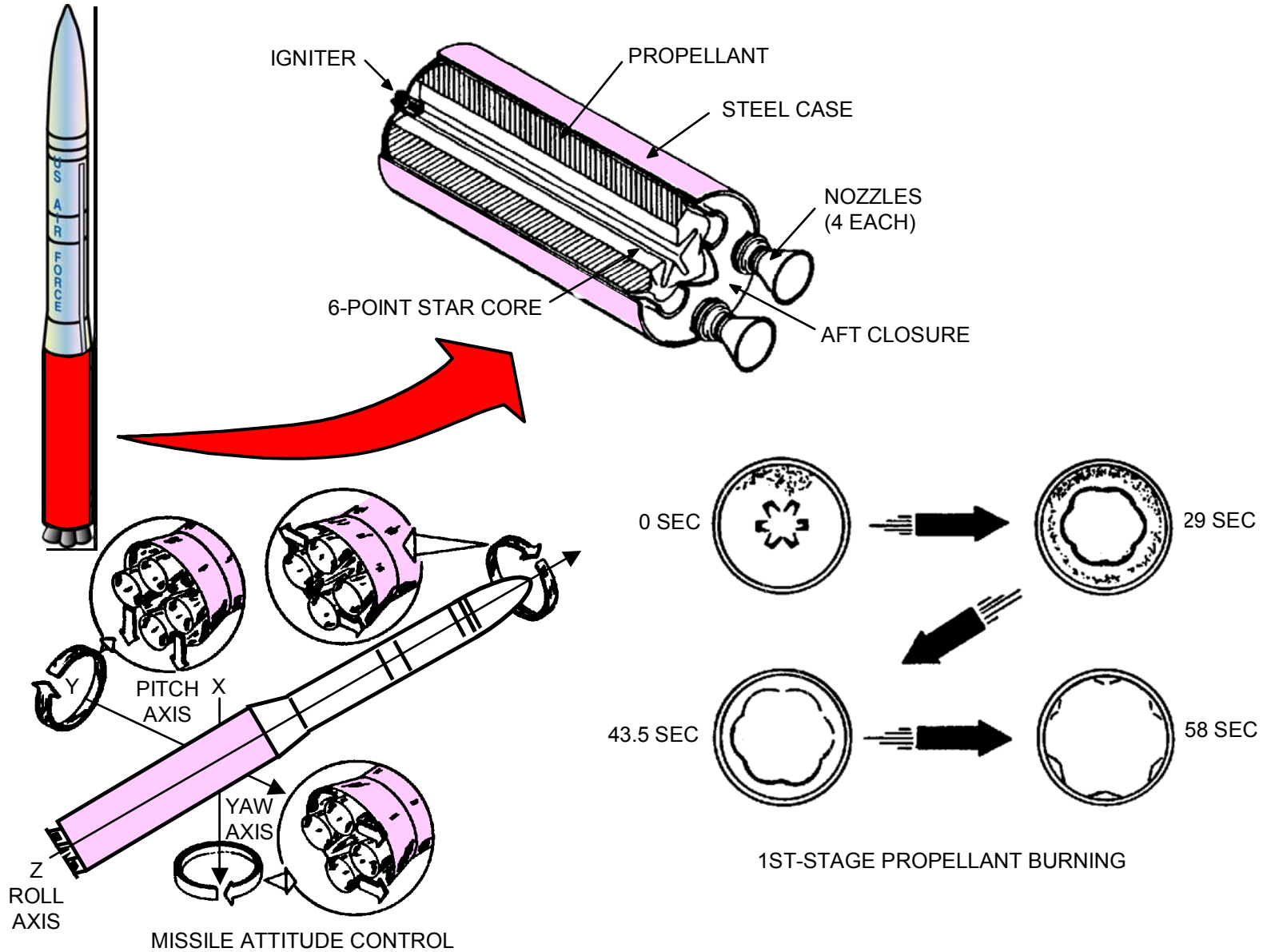

# MINUTEMAN III PROPULSION SYSTEM ROCKET ENGINE

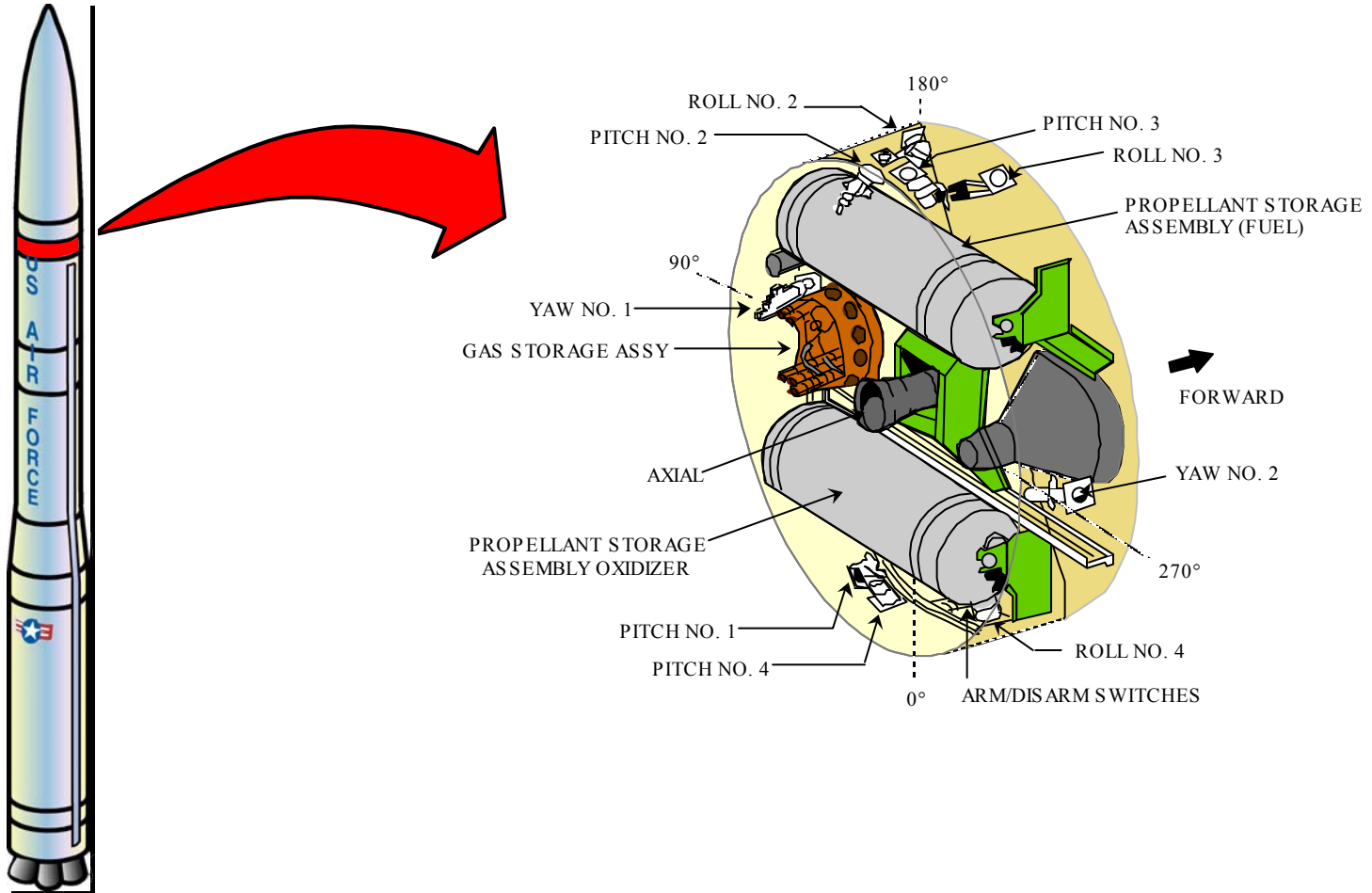





# ***GUIDANCE SYSTEMS***

The Autonetics Division of Rockwell International produced all three generations of the Minuteman MGS as well as modifications to these systems (the division is now a part of the Boeing Company). The MGS is an inertial guidance system which directs the flight of the missile. The MGS includes the flight computer/amplifier, Gyro Stabilized Platform (GSP), and Missile Guidance Set Control (MGSC), and the Amplifier Assembly. The MGS is an inertial guidance system which directs the flight of the missile. The guidance system operates continuously while the missile is in alert status, thus enabling the missile to be launched in less than one minute.

Once the missile is launched, the guidance system cannot be changed or affected from the ground, a feature which prevents enemy interference with the planned trajectory of the missile.

During first-stage flight, the MGS flight computer sends commands to the NCU to keep the missile on the precise course required for the RVs to reach their designated targets. At the proper instant, the computer sends commands which separate an almost exhausted motor from the missile, and ignites the next stage motor. The computer then sends steering commands to the TVC Unit of each succeeding motor stage to keep the rocket on course.

The incorporation of current-technology electronics with each generation of the guidance system has resulted in a more capable and less vulnerable system. The NS-50 design developed by Boeing under the Guidance Replacement Program (GRP) will be completely fielded by 2008. The figure below shows the location of the major components in the Minuteman III MGS for the current NS-20 guidance system. The NS-50 design is functionally similar. The colored areas show those items that are being changed by the NS-50 design. The next four charts briefly describe the principal components of the Minuteman guidance system.

# MINUTEMAN III GUIDANCE SYSTEM

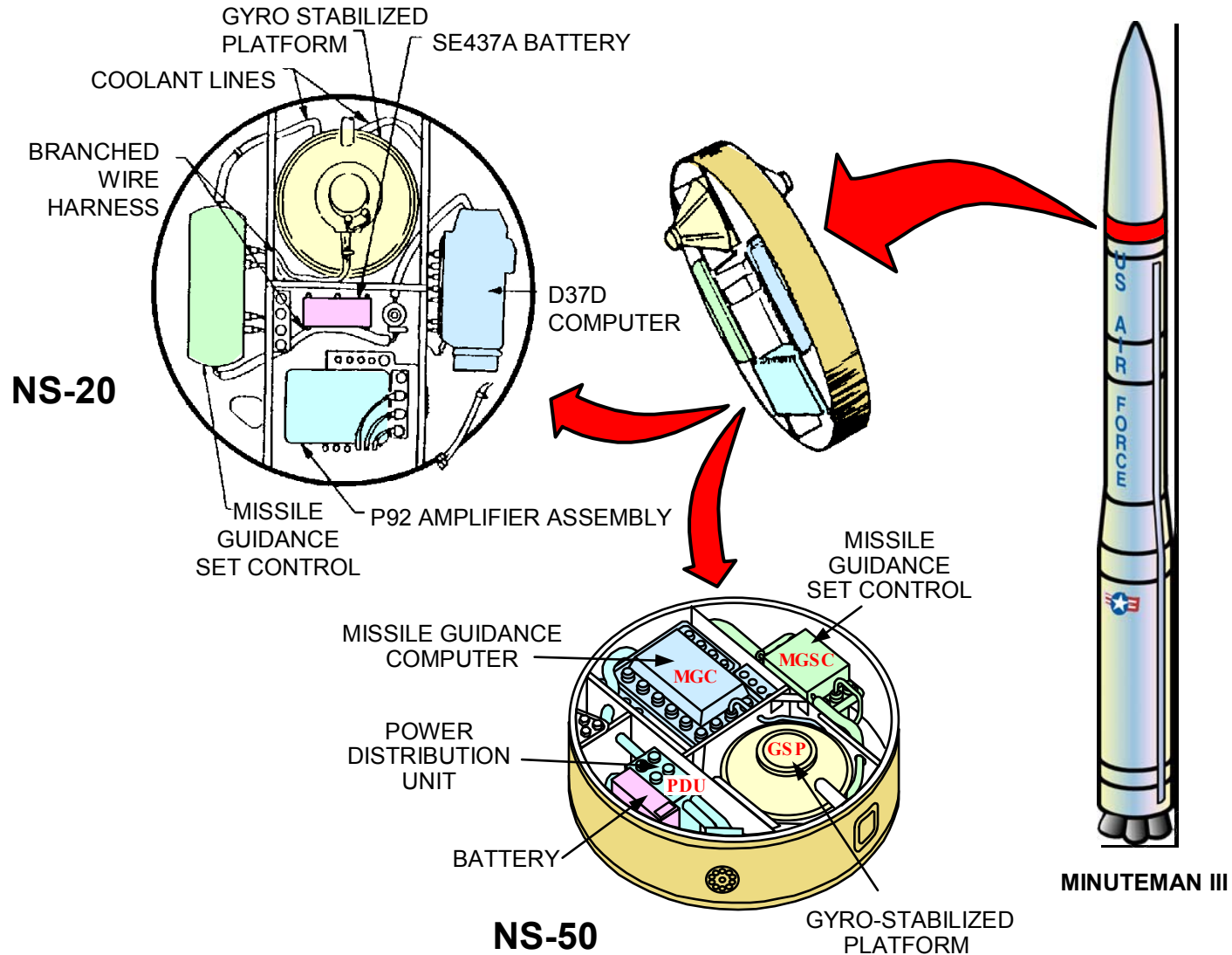



# ***MINUTEMAN III GYRO STABILIZED PLATFORM***

The GSP measures acceleration and transforms it to velocity which is provided with attitude information to the guidance computer during flight. This data is required so that accurate and proper flight control of the missile is obtained. The GSP also provides level detector and gyrocompass information and accepts control signals so that platform attitude constants are obtained and the platform is properly aligned prior to missile launch.

The Minuteman GSP uses an external gimbal configuration. The platform is stabilized by two dual-axis, free-rotor gyros whose rotors are supported on self-generated gas bearings. One gyro serves as the pitch and roll axis stabilization reference; the other provides an azimuth stabilization reference (the remaining axis is electrically caged).

The dual-axis gas bearing gyro was selected because of its dynamic stability over extended operation periods and its ability to withstand high g loads. Use of self-generated gas bearings means that some wear will take place whenever the G&C section is shut down and restarted. During start-up, a much higher than normal voltage is applied to accelerate the gyro rotors quickly and generate the gas "cushion." Capacitance-type pickoffs are employed to detect displacement of the gyro case relative to the spinning rotor.

The stable platform carries three Pendulous Integrating Gyroscopic Accelerometers (PIGAs) to measure missile acceleration along each of its three axes. Each accelerometer contains a gyroscopic pendulous mass which is floated in liquid to minimize bearing load and friction.

Acceleration along the sensitive axis of an accelerometer displaces its mass, which causes a pickoff to generate a signal. This signal, through closed servoloop mechanization, applies a rotation of the Pendulous Integrating Gyroscope (PIG) sufficient to cause the force on the mass to be countered by precession. The angle through which the PIG has been rotated is proportional to the integrated acceleration (velocity gained and gravity) along the input axis.

# MINUTEMAN III GYRO STABILIZED PLATFORM

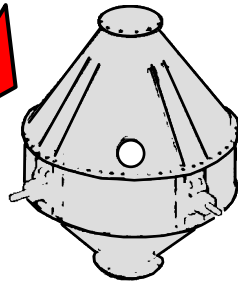

STABLE PLATFORM HOUSING

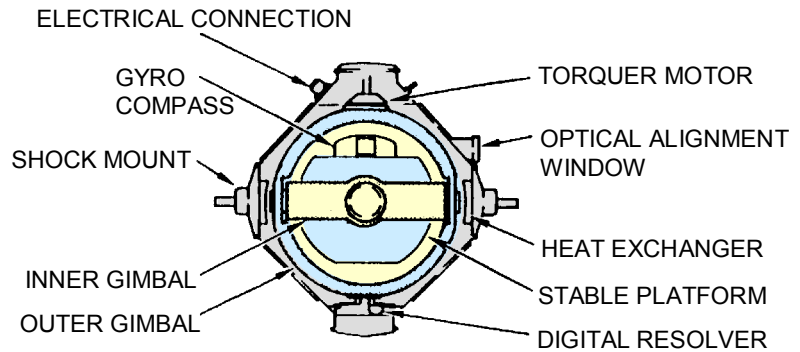

CROSS SECTION OF  
STABLE PLATFORM IN HOUSING

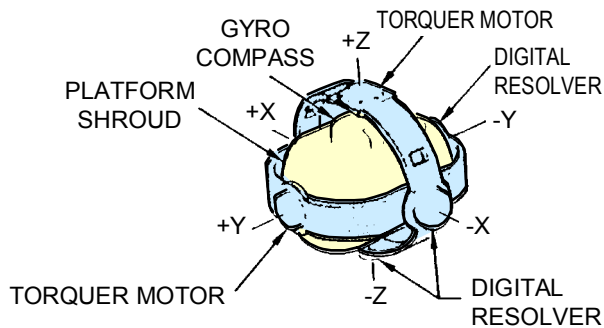

STABLE PLATFORM AND GIMBALS

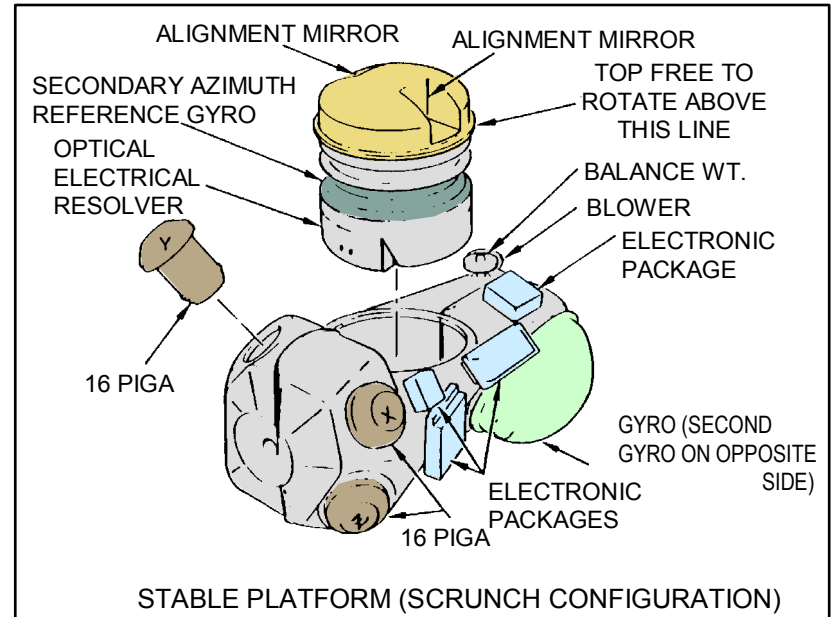

STABLE PLATFORM CONFIGURATION



# ***MINUTEMAN III FLIGHT COMPUTER***

The NS-20 D37D flight computer is a miniaturized general purpose (serial transmission) digital computer. The new NS-50 missile guidance computer (MGC) is built around a 16-bit high-speed microprocessor chip set. They are both designed to solve real-time positional error problems under the adverse conditions encountered in airborne weapon systems. They accept and process data and generate steering signals with sufficient accuracy and speed to meet the requirements of the inertial guidance and flight control systems of the Minuteman ICBMs. Computer operation is controlled by an internally-stored program which is loaded from a magnetic tape cartridge at the LF.

Both the D37D computer and the MGC are designed and programmed to control the Minuteman III missile throughout the powered portion of flight. After thrust termination they also control the PBV for the RV deployment phase. In addition, they control the alignment of the inertial platform and test/monitor the G&C system and other components to determine continued readiness while missiles are in alert status. The D37D computer began to be replaced by the MGC in 2000 as part of the Guidance Replacement Program (GRP), with fielding planned through 2008. The MGC incorporates the amplifier assembly functions.

When a launch is commanded, a complete retesting of the G&C system is made prior to entering the flight program. During flight, the computer uses missile attitude, change of attitude rate, and velocity signal inputs to solve a series of guidance, steering, and control equations. It also generates missile steering commands and controls staging and thrust termination. Finally, the computer determines whether or not to provide pre-arm signals to the warhead. The pre-arm decision is based on flight safety checks made during powered flight.

# MINUTEMAN III FLIGHT COMPUTER

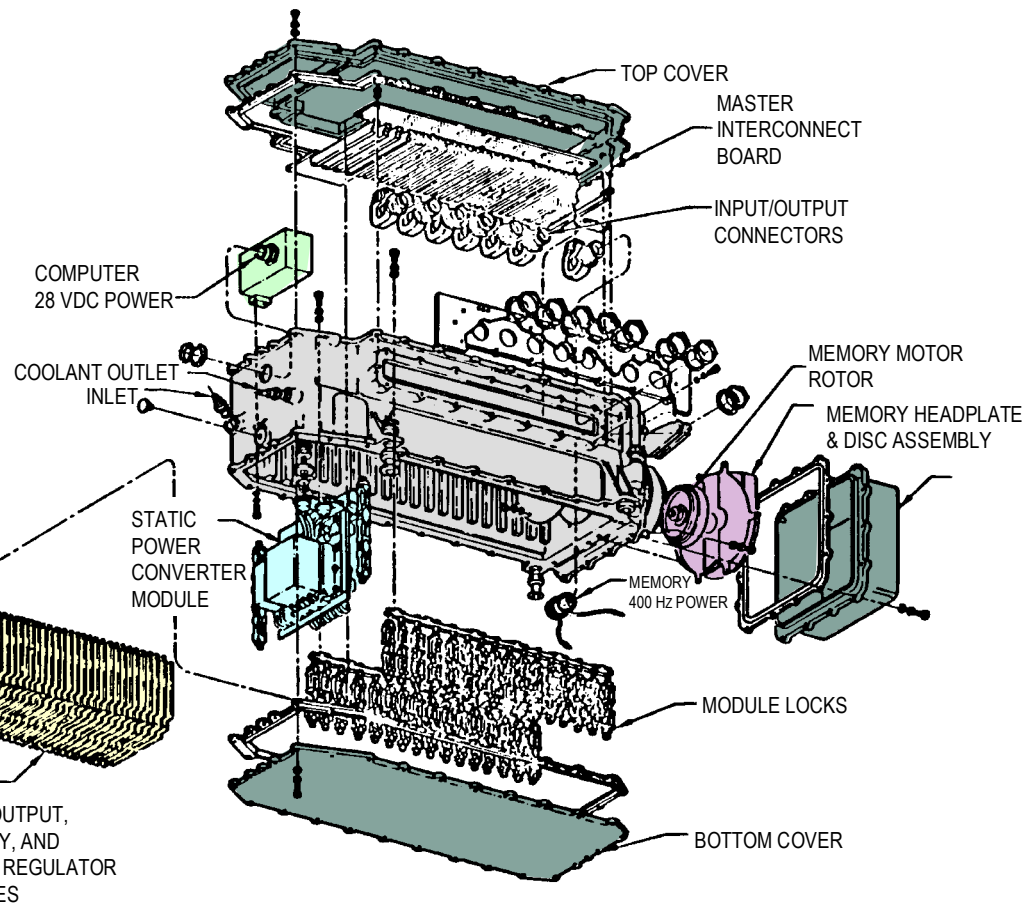

NS-20 (D37D)

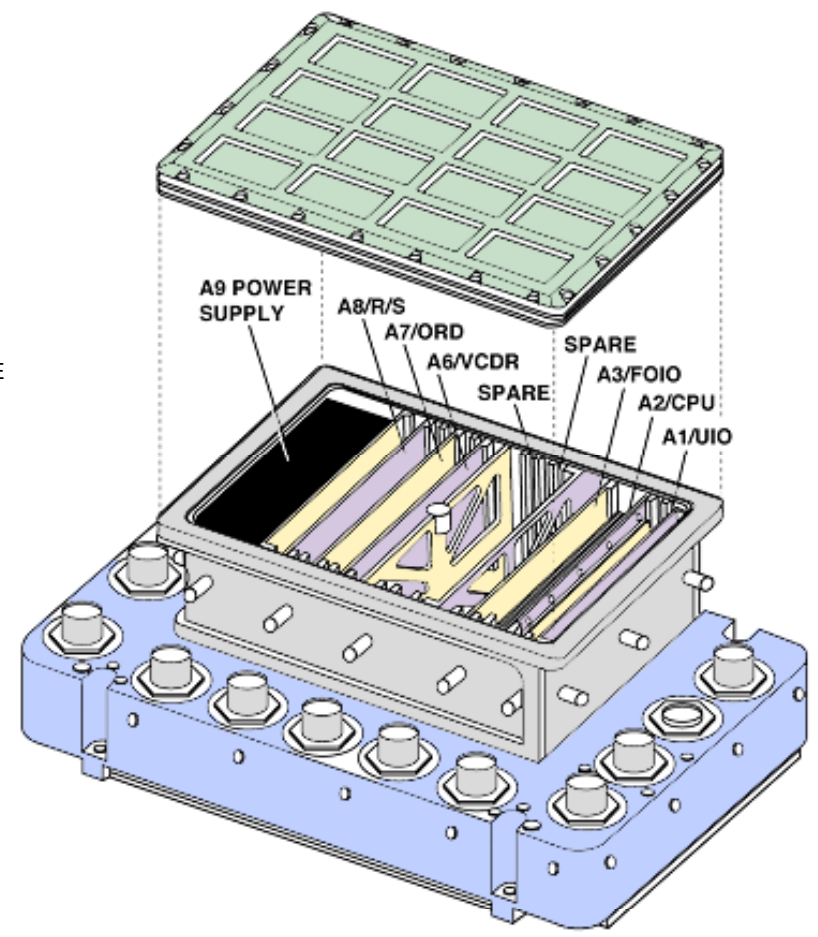

NS-50 MGC (GRP)



# ***MINUTEMAN III MISSILE GUIDANCE SET CONTROL (MGSC)***

The MGSC electronically interfaces with the flight computer and the GSP, and provides all power for the IMU the NS-20 MGSC also supplies 400 Hz memory power for the D37D computer. The new NS-50 MGSC communicates with the MGS through a time-multiplexed serial interface similar to the Peacekeeper IMU/computer interface. In conjunction with the computer and platform-mounted instruments and electronics, the MGSC provides platform control in the form of:

- Platform Servo
- Gyro Torquing
- Accelerometer Servo
- Gyro Compass Assembly (GCA) Torquing and Slew
- Gyro, Accelerometer, and GCA Speed
- Accelerometer Temperature

The MGSC has also been redesigned by the GRP

# MINUTEMAN III GUIDANCE SET CONTROL

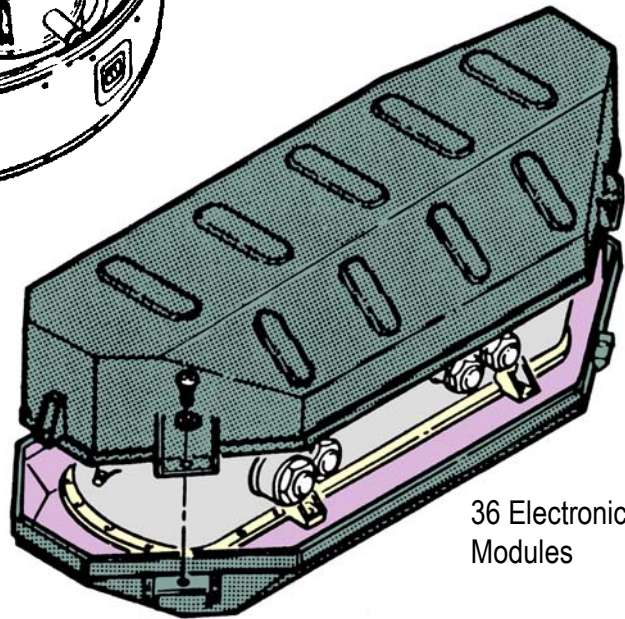
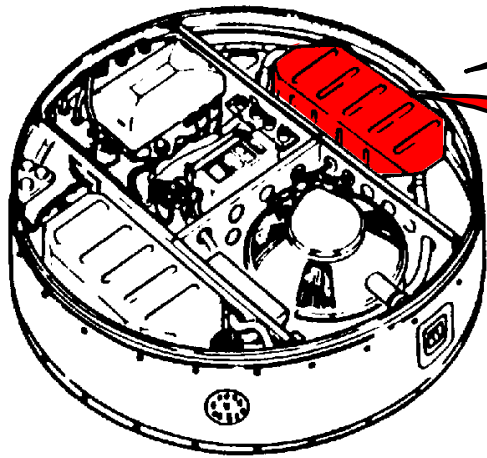

NS-20 MGSC

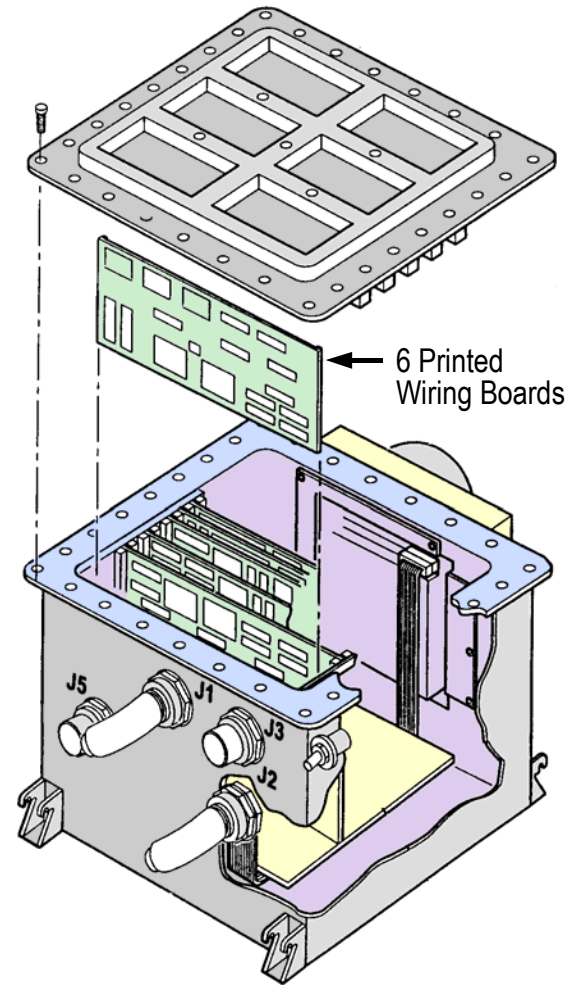

NS-50 MGSC





# ***MINUTEMAN III P92 AMPLIFIER***

The P92A3 Amplifier electrically couples the D37D computer (NS-20 only) with the missile downstage and the RS, providing missile attitude and event control during flight and serving as an Aerospace Vehicle Equipment (AVE) safety control device. Acting on steering, stage selection, and ordnance initiation commands received from the computer, the P92 issues amplified signals to valves, actuators, and ordnance devices. Unless the P92 is armed by an appropriate code, all ordnance initiation output signals are disabled (grounded). The assembly comprises a case, electronic modules, and an interconnect board. The functions of the current P92A3 have been incorporated into the NS-50 MGC during GRP.

# MINUTEMAN III P92A3 AMPLIFIER ASSEMBLY

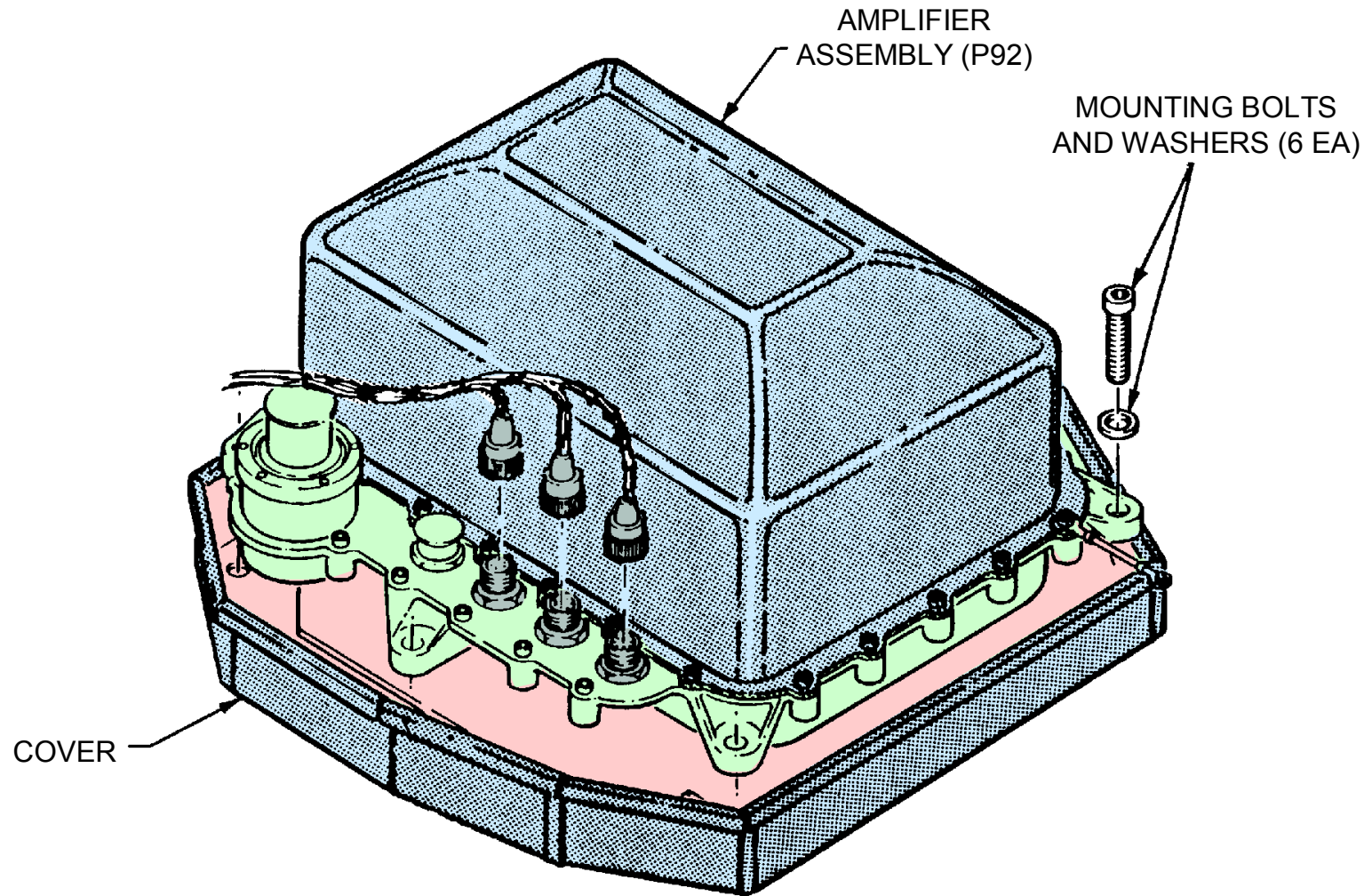



# **REENTRY SYSTEMS**

The Minuteman III RS was originally designed and produced by General Electric to deploy two or three MK 12 RVs. In the late 1970s the MK 12 RS was modified to accommodate a new RV, designated the MK 12A. Three hundred of the original 550 MK 12 systems were converted to the MK 12A configuration. In the 1990s the capability to deploy a single RV was added to the existing multiple interdependently target reentry vehicle (MIRV) capability to allow strategic planners greater flexibility in meeting warhead reductions mandated by arms limitation treaties. A future modification is being planned to deploy either one or two MK 21 RVs on Minuteman III when the Peacekeeper system is deactivated.

During a typical flight mission, the RS Shroud is removed from the RS near the end of Stage 2 burn. Following Stage 3 thrust termination, the RS is maneuvered by the PBV to an independently-targeted RV deployment station for each RV. Following transmission of required signals for timing and warhead arming from the computer in the MGS, the RV is separated electrically and mechanically from the PBV. The deployed RV is “spun up” by gas generators in the RV aft section as the PBV completes a maneuver to back away from the deployed RV en route to the deployment station for the next RV.



# REENTRY SYSTEMS

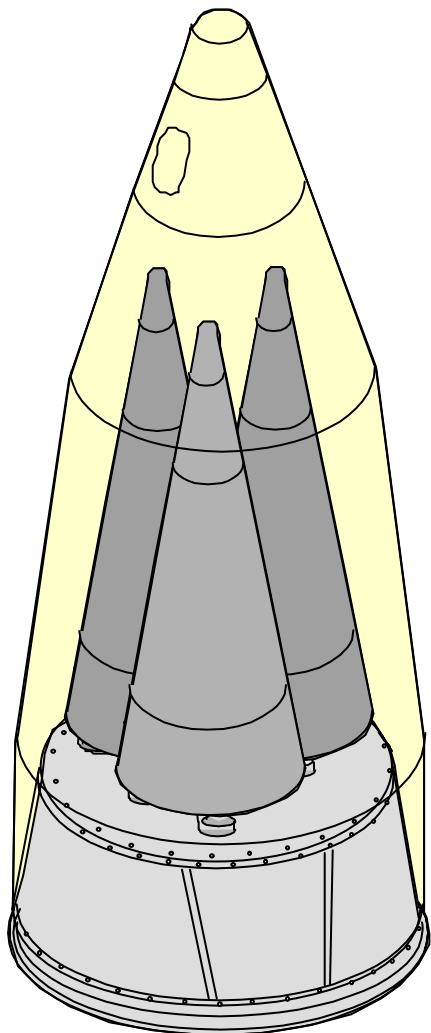

**2-3 RV  
EXISTING**

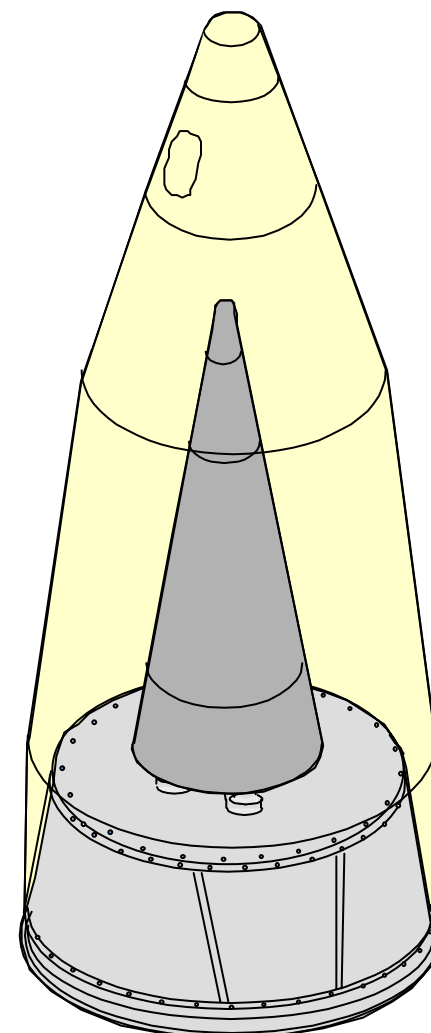
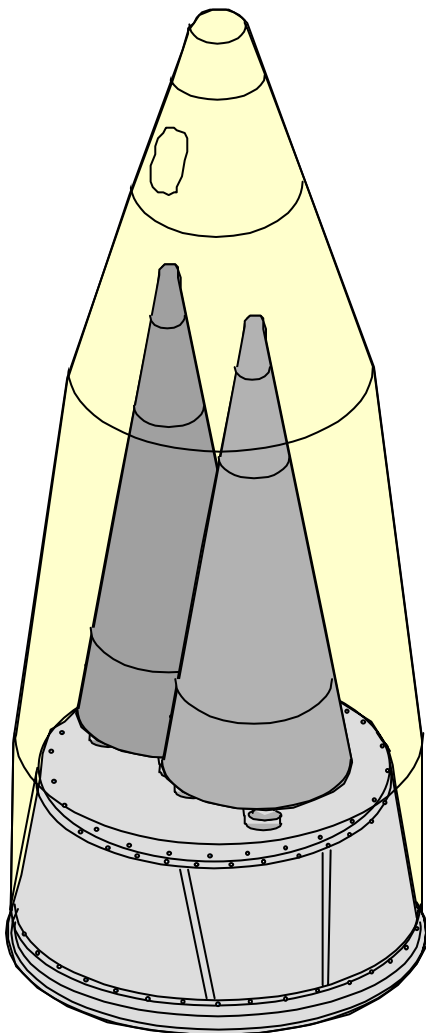

**1 RV  
MODIFIED**





# **MARK 12/12A REENTRY SYSTEMS**

The MK 12 and MK 12A RSs consist of a shroud assembly, deployment module, RVs, penetration aids, and ordnance devices (see Ordnance, Section Four).

The shroud assembly consists of a forward and aft shroud which provides environmental protection for the RVs, penetration aids, electronic components, electrical harness, and ordnance during powered flight. A rocket motor, located in the forward shroud, provides sufficient impulse to separate the shroud assembly from the deployment module during second stage burn at a predetermined altitude. The shroud assembly is attached to the deployment module by a V-band clamp, which is separated just prior to rocket-motor ignition.

The RV is a high-performance ballistic envelope secured to the support payload bulkhead. The RS installation kit provides the mounting and support fittings for mounting up to three RVs to the bulkhead and the electrical interconnection between the RVs and electronic components mounted in the deployment module.

The RV consists of forward, aft, and mid-sections joined together by breech lock threads. The external surfaces of the RV are composed of ablative carbon-phenolic heat shield material, with the exception of the central portion of the aft-section cover which is protected with elastomeric shield material, and the nose tip which is carbon-carbon. Surface contours and composition of the shield are designed to achieve minimum radar cross section and to protect internal assemblies from reentry heat. A hot gas spin system, located in the aft section, stabilizes the RV in its correct reentry orientation after deployment. The RV contains the arming and fuzing assembly which provides various height-of-detonation targeting options. The mid-section contains the warhead. Minuteman III employs two different RVs, the MK 12 deployed at Malmstrom AFB, MT and F.E. Warren AFB, WY, and the MK 12A deployed at Minot AFB, ND, and Malmstrom AFB, MT (Squadron 20).

The penetration aids consist of two chaff dispensers and the chaff attachment kit. Each dispenser is an electromechanical device which stores the chaff and dispenses it in the required pattern (cloud geometry). The chaff consists of numerous dipoles of varying lengths which are released in groups in response to discrete signals from the MGS. The discrettes and electronic controls govern the ejection velocity and feed rate. The chaff attachment kit consists of the mechanical attachment fixtures, electrical harnesses, and electronic control and power distribution components.



# MARK 12/12A (TYPICAL)

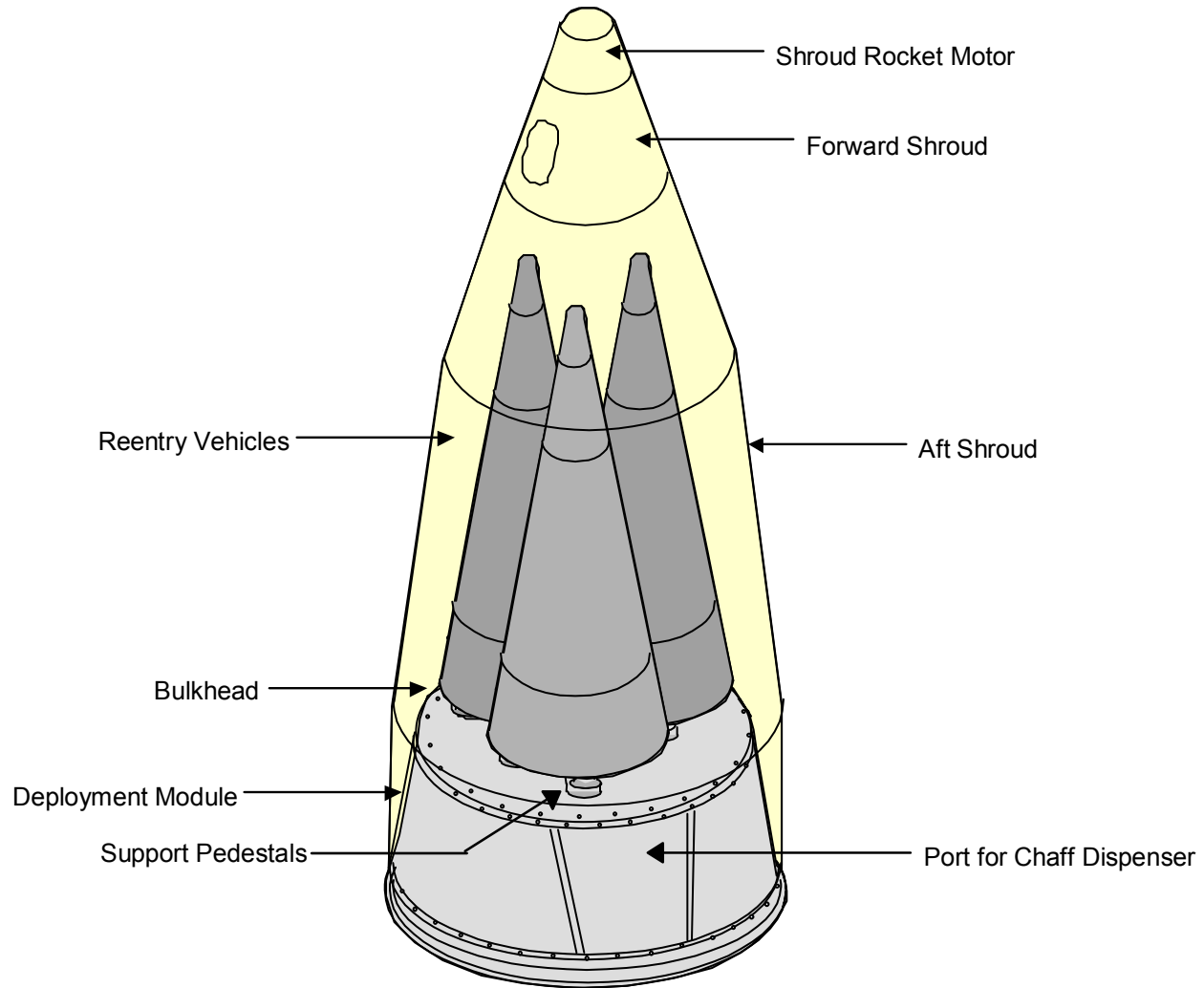

# LAUNCHER SUPPORT BUILDING (WS-133A-M)

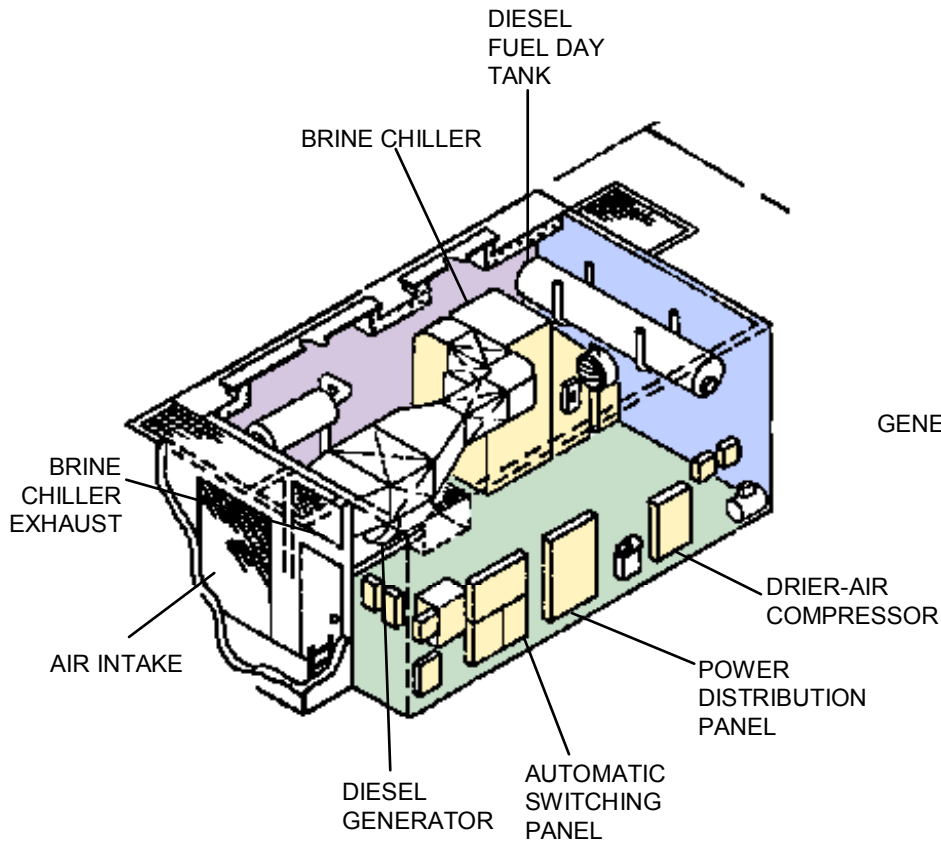

**WING I**

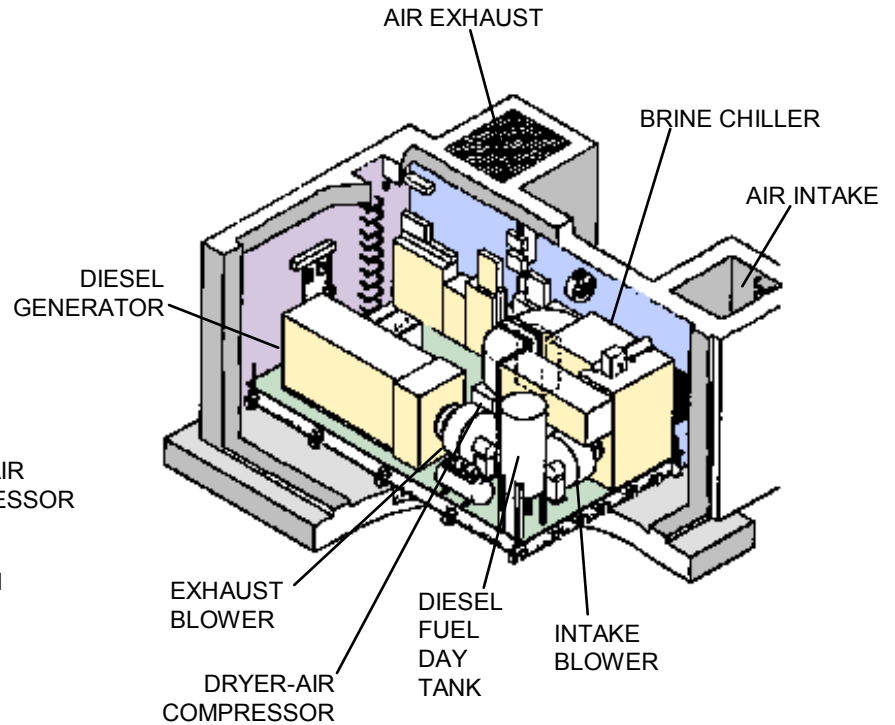

**WINGS III, V  
(TYPICAL)**



# ***LAUNCHER EQUIPMENT BUILDING (WS-133B)***

In the WS-133B System, the Launcher Equipment Building (LEB) is a hardened underground structure of reinforced concrete and steel designed to survive nuclear weapon effects. The LEB is located adjacent to the launcher. A vertical shaft with a removable cover and two steel hatches provides access. A blast door separates the LEB from the access shaft. Support equipment in the building is mounted on a shock-isolated floor and includes: 1) the service entrance for the commercial power source; 2) the three-phase 60-Hz standby diesel engine-generator complete with voltage sensing, phase sensing, voltage regulating, and automatic starting and stopping equipment; and, 3) the brine chiller for the environmental control system.



# LAUNCHER EQUIPMENT BUILDING (WS-133B)

Wing I Squadron 20

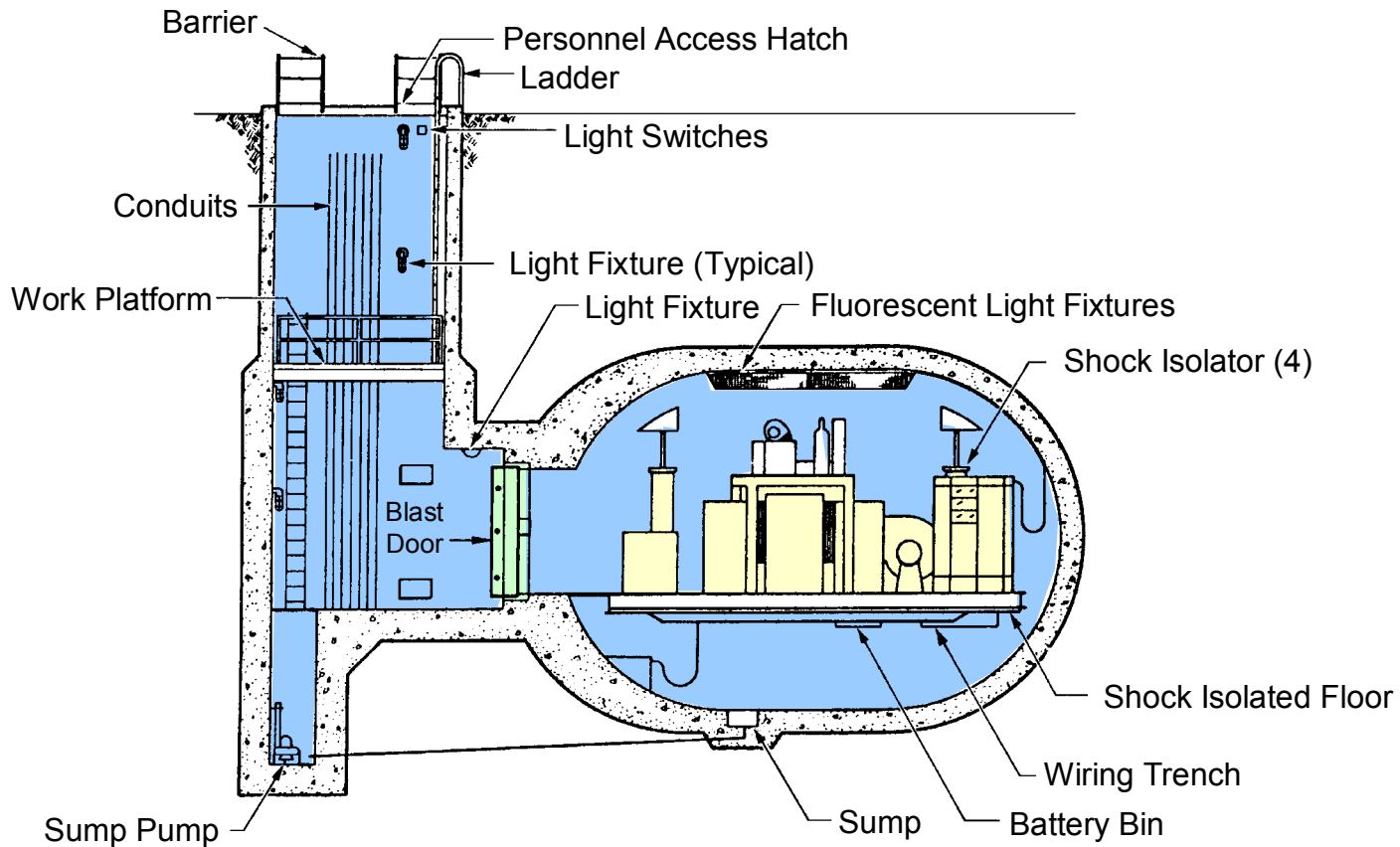



# ***LAUNCH FACILITY SECURITY SYSTEM***

The function of the security system is to detect unauthorized activity at the LF. The system is divided into outer and inner zone functions. All detected security violations are displayed on a status console in the LCC. The earlier outer zone security systems experienced excessive nuisance and false alarm rates, and the system mean-time-between-failure (MTBF) rates were significantly below the specified 37,000 hours. To solve this problem, an Improved Minuteman Physical Security System (IMPSS) was developed and installed at all six wings as part of the Rivet Minuteman Integrated Life Extension (MILE) program during 1987 to 1992. The modification replaced the bistatic radar system and alarm set electronics (outer zone protection) with a single monostatic radar system where the transmit and receive elements are contained in a single mast located near the launcher closure.

The security inner zone system includes switches on the launcher closure and locking pin, the primary door, combination locks on the primary door, security switches on the secondary door, and penetration detection devices on the vault door. In addition, vibration-sensitive transducers are strategically located within the launcher.

# LAUNCH FACILITY SECURITY SYSTEM (TYPICAL)

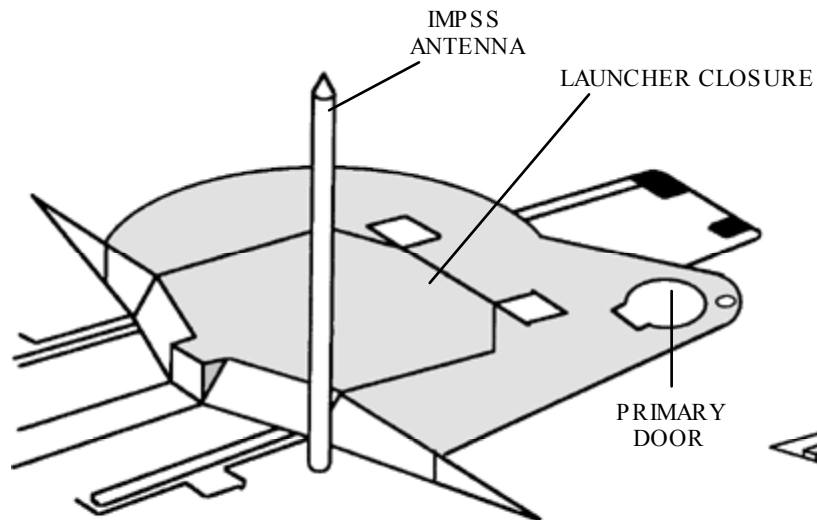

**OUTER ZONE SECURITY**

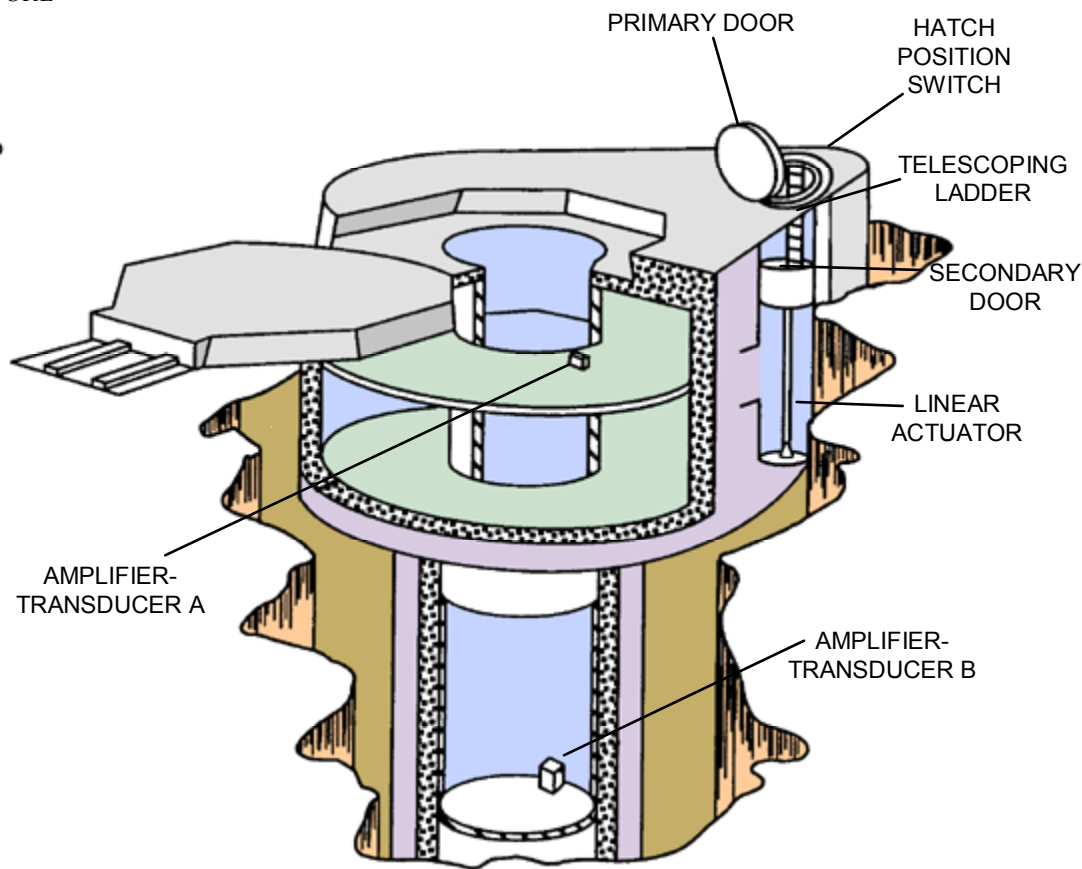

**INNER ZONE SECURITY**



## **SECTION FOUR**

# ***MINUTEMAN ORDNANCE***

This section provides an overview of Minuteman Ordnance. The primary ordnance applications include motor igniter, interstage, reentry system (RS)/penetration aids, and operational ground equipment (OGE). In addition guidance and flight control ordnance include squib-initiated batteries and the critical lead disconnect switch. The critical lead disconnect switch for example is used to cut critical computer lines to prevent inadvertent signals to the computer at the time of umbilical disconnect. Each of the main ordnance types are discussed in the following charts. (The figure below is a Stage 2 igniter.)



# ***INTERSTAGE ORDNANCE***

One of the most essential groups of small ordnance items on the Minuteman weapon system is the interstage ordnance hardware. These staging and thrust termination devices are ordnance charges which are fired by the flight computer at the required points in boost flight. They must operate reliably, for they must fire in a proper sequence to remove the various interstages at the appropriate times to ensure mission requirements are met. These explosive devices consist of detonators, squibs, linear-shaped charges, delay timing devices, etc. Arm/Disarm (A/D) ordnance are placed on the interstages to allow separation of stages with minimum missile interference. Ignition Safety and Arming (S&A) ordnance are located at the front of each motor to provide stage ignition. The missile interstages provide structural continuity between rocket motors and retain structural integrity during ground handling, launch, and flight environments. They also provide for safing pin installation and removal, G&C cabling, and the installation and removal of the explosive kits. The interstage skirts provide heat shielding for interstage equipment (including motor nozzles) during flight operation. The design of the interstage provides severance capabilities for stage separation and skirt removal.

The interstage explosive kits consist of the body section separation linear explosive assembly, a detonator assembly, two item delay boosters, a mechanical (lanyard operated) S&A device, a crossover booster, a skirt-removal circumferential linear explosive assembly, and four skirt removal longitudinal linear explosive assemblies.

Upon receipt of the computer-generated electrical signal which occurs simultaneously with second-stage rocket motor ignition, the 1-2 interstage stage separation explosive kit severs the longitudinal tension members near the second-stage nozzle exit plane. The interstage skirt is jettisoned 14 to 22 seconds after Stage 2 rocket-motor ignition.

After receipt of a the computer-generated electrical signal, the 2-3 interstage separation explosive kit severs the longitudinal tension members near the third-stage nozzle exit plane and jettisons the interstage skirt about one second after Stage 3 motor ignition.

# S&A and A/D Switch Locations

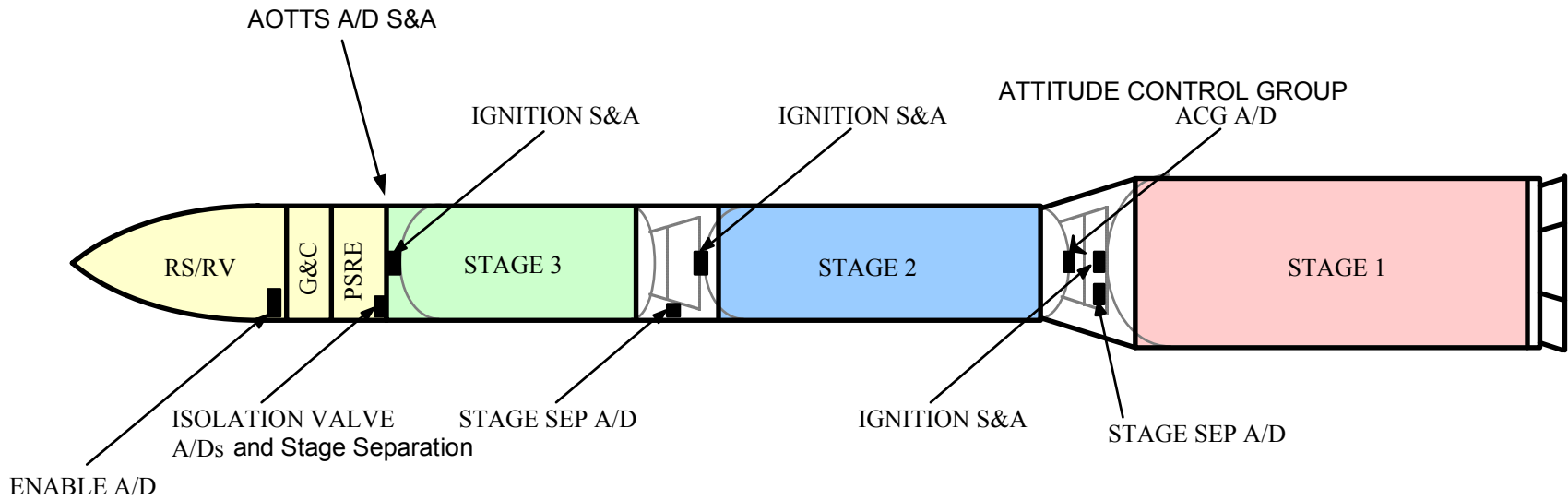



# ***THRUST TERMINATION SYSTEM ORDNANCE***

The Thrust Termination System Ordnance, on command from the guidance system, opens ports in the Minuteman II and III third-stage motors. This results in reduced motor pressure and provides reverse thrust for third-stage deceleration and separation from the post-boost vehicle (PBV).

For Minuteman III, the TT system, called the All-Ordnance Thrust Termination System (AOTTS), consists of six equally spaced TT ports placed at the top of the rocket motor. Installed at the base of each AOTTS port next to the top of the motor case is a ring assembly consisting of a retaining ring, linear-shaped charge (LSC), charge retainer, and other miscellaneous hardware. When TT is initiated by the guidance system, a firing signal is sent through the A/D device to the LSC. A plasma jet from the LSC cuts through the motor case, allowing the motor combustion gases to escape through the TT stacks. This causes deceleration of the third stage and positive separation from the PBV containing the RVs.

# THRUST TERMINATION SYSTEM ORDNANCE

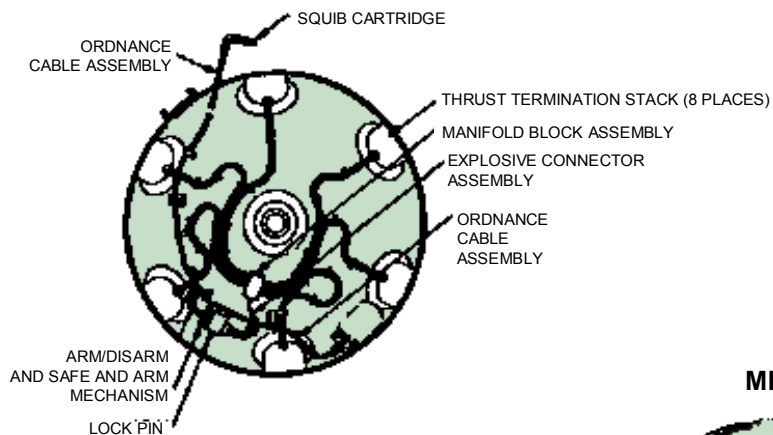

**THRUST TERMINATION  
ORDNANCE**

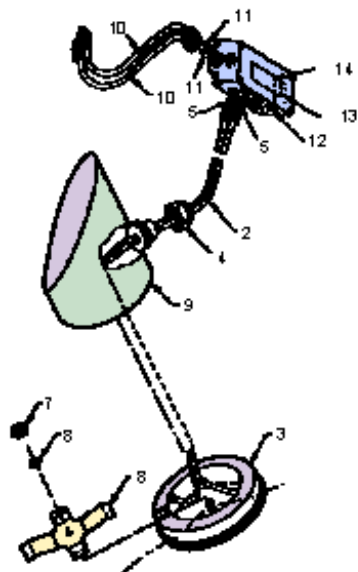

**MINUTEMAN III STAGE 3 MOTOR**

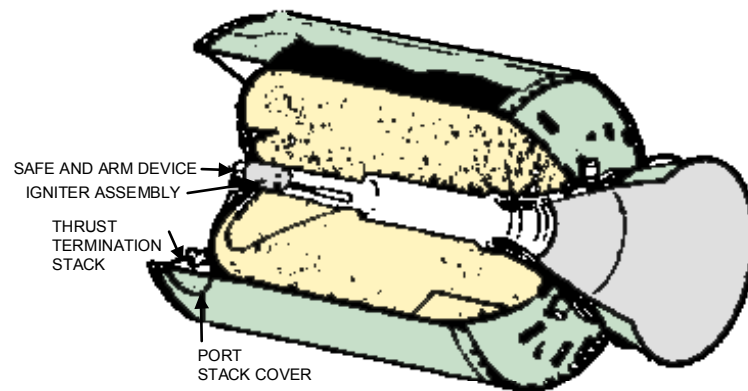





# ***REENTRY SYSTEM ORDNANCE***

Reentry system (RS) ordnance includes pitch and spin rockets, gas generators within the separation system, and electrical cable separation squibs. Failure of any one of the RS ordnance devices would not cause a critical reliability failure, but would degrade the effectiveness of the Minuteman mission.

Penetration Aids ordnance includes small rockets, fuses, detonators, squib cartridges, gas generators, linear-shaped charges, and delay timing devices. Penetration of the RV is enhanced by deployment of the Pen Aids countermeasures by the ordnance hardware.

# REENTRY SYSTEM ORDNANCE

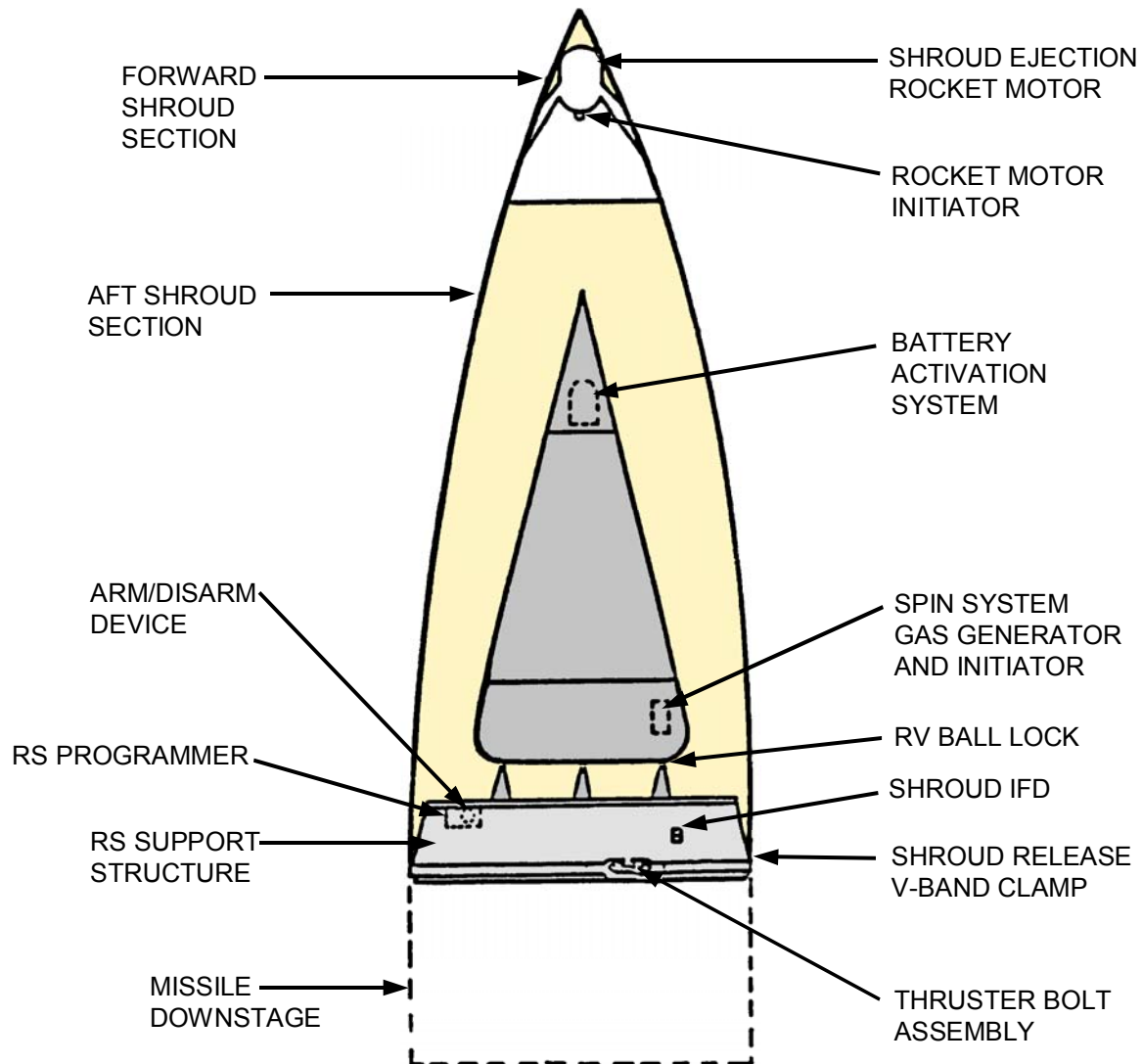



# ***OPERATIONAL GROUND EQUIPMENT ORDNANCE***

Minuteman OGE ordnance includes: 1) the silo door gas generators, which force the silo door ballistic actuator piston downward to remove the launch-tube closure; 2) the Umbilical Release System (which includes (a) the impulse cartridge (shown below) for providing gas pressure to retract the guidance and control (G&C) umbilical connector and cable prior to missile launch, and (b) the cable squib which disengages the umbilical cable from the missile); and 3) the articulating arm explosive bolts, which cause the six arms to deploy against the launch tube wall and center the top of the missile suspension system within the launch tube.

The silo door gas generators are considered the most critical OGE items, since malfunction of these ordnance items would prevent a missile launch. The umbilical release system is next in respect to criticality. However, there is a high probability if this system malfunctioned the missile would fly away from the umbilical and complete its mission.

# IMPULSE CARTRIDGE

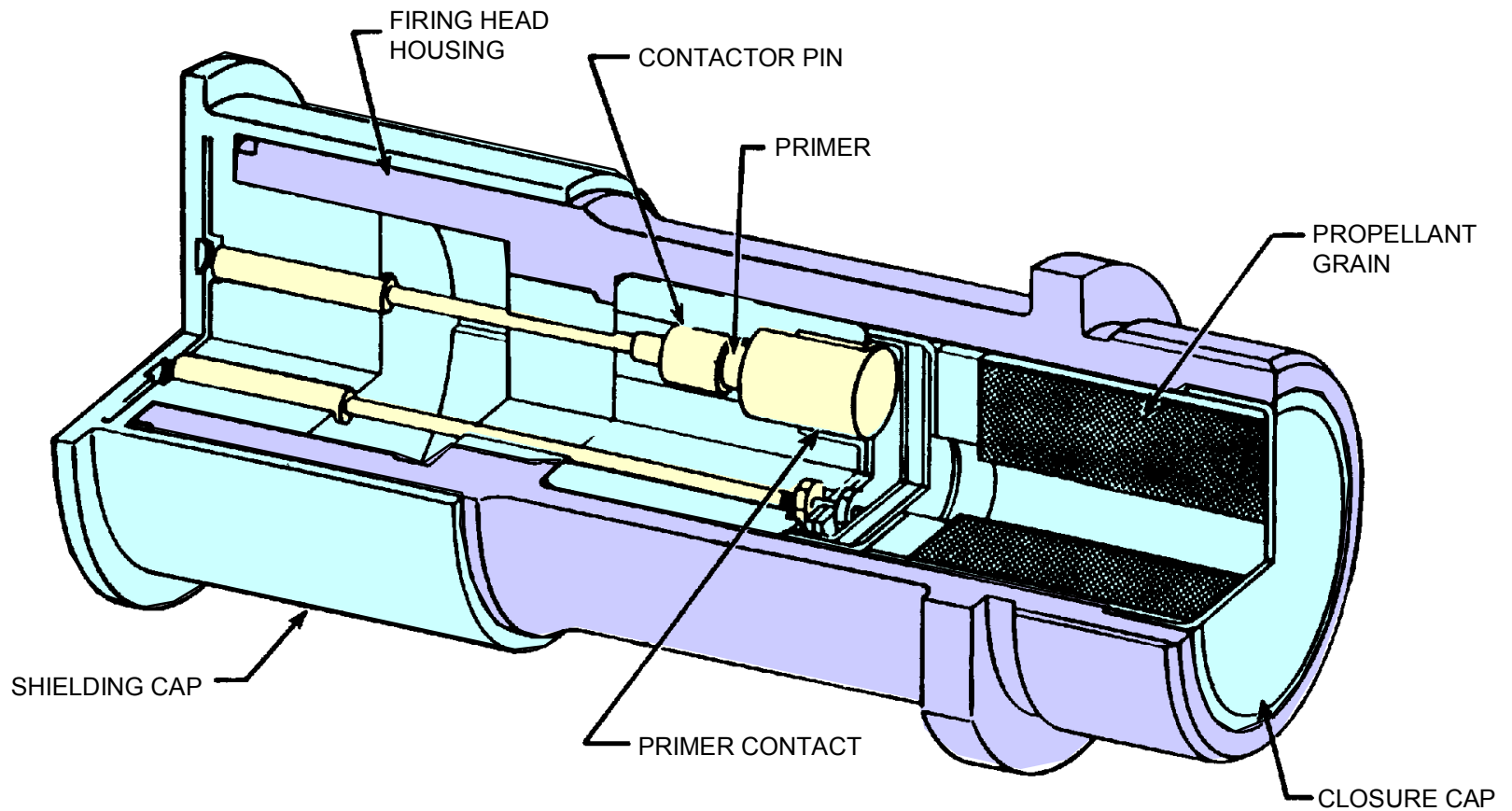



## **SECTION FIVE**

# ***CHRONOLOGY OF MINUTEMAN DEVELOPMENT AND DEPLOYMENT***

A detailed chronology of Minuteman development and follow-on improvements is presented in the next few charts.



# MINUTEMAN CHRONOLOGY

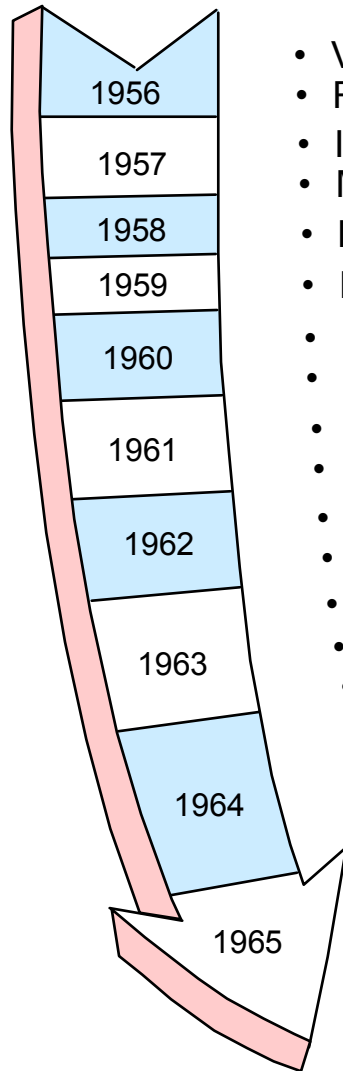

- Von Neumann Committee approved Ballistic Missile feasibility program
- R&D programs and contracts authorized
- ICBM improvements studies started
- Minuteman configuration studies started
- Minuteman R&D program authorized
- First R&D firing from silo - inert second and third stage
- First contract for operational wing facilities at Wing I
- Missile production
- First all-up missile launch from pad at Eastern Test Range
- First missile launch from silo at Eastern Test Range
- First missile launch from Western Test Range
- Minuteman I operational flight turnover at Wing I
- First wing turnover at Wing I, Wing II turnover
- Force Mod program approved
- First motor static test firing to verify reliability
- Wing III and IV turnover
- New features approved
- Minuteman II flight test
- Giant boost
- Wing V turnover
- Vulnerability improvements
  - Minuteman fully operational at Wing II, III

# MINUTEMAN CHRONOLOGY (Cont'd)

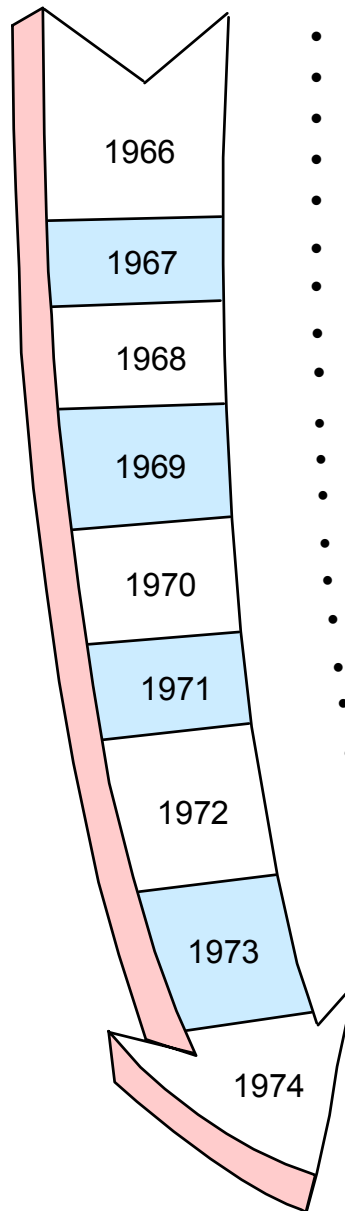

- Wing VI turnover
- Minuteman III approval
- Aging surveillance program initiated
- Minuteman II operational at Wing VI
- ERCS deployed
- Squadron 20 turnover
- Force Mod at Wing IV
- Hard rock silo program started
- First Minuteman III R&D flight
- Force Mod rate decrease
- Force Mod at Wing I completed
- Service Star testing began for RSs
- First Minuteman III at Wing III
- Upgrade silo and CDB programs started
- First MOM test at Wing VI
- Minuteman III dust program started
- Force Mod at Wing III completed
- Minuteman III deployed at Wing VI
- First dust hardened Minuteman III deployed at Wing VI
- Minuteman ordnance service life analysis program developed
- Responsibility for service life testing transferred to OO-ALC
- Upgrade silo and CDB IOC at Wing V
- Force Mod and upgrade silo completed at Wing II
- Last MOM at Wing III
- Full Force upgrade silo approved
- MK 12A and Pave Pepper programs started
- SSAS was deployed for Minuteman II

# MINUTEMAN CHRONOLOGY (Cont'd)

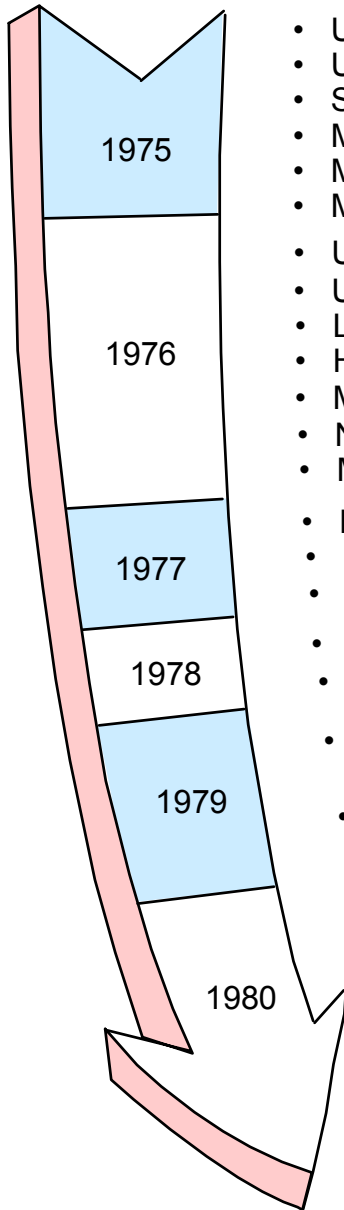

- Upgrade silo and CDB completed at Wing V
- Upgrade silo and CDB start at Wing III
- Simulated electronics launch Minuteman program started
- Minuteman bench test program concept developed by OO-ALC
- Minuteman III fully deployed
- Minuteman program management responsibility transfer (PMRT)
- Upgrade silo and CDB completed Wing III
- Upgrade silo and CDB completed Wing VI
- Long range service life analysis performed for propulsion system
- Hybrid explicit implemented for Minuteman III
- Minuteman II MGS vibration test program initiated
- New calibration schedule implemented to correct MGS startup transients
- Minuteman II Stage 3 lot 16 motor igniters replaced
- Minuteman III missile production terminated
- Inertial performance data began to be collected for guidance system fault isolation
- Began implementation of ILCS at Minuteman II Wings
- GIP implemented at Minuteman III
- Thrust termination port investigation began
- Minuteman II Stage 2 motor remanufacturing program began to correct degraded liner/Minuteman III Stage 3 degraded liner investigation initiated
- USAF advisory board recommended that carbon-carbon nose tips be developed for MK 12 RVs
- Upgrade silo and CDB completed at Wing VI
- Minuteman II accuracy/reliability investigation was conducted
- VRSA replacement design started
- Diagnostic data package hardware delivered to provide re-entry/separation data for Minuteman II flights



# MINUTEMAN CHRONOLOGY (Cont'd)

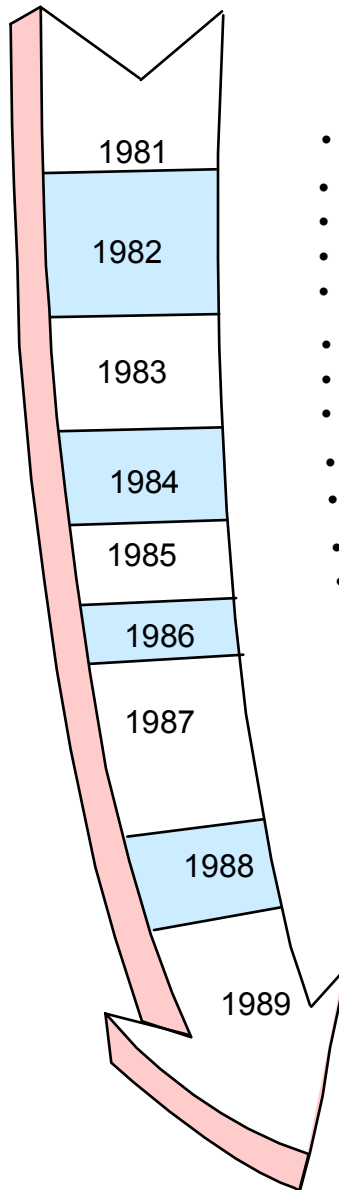

- MGS electronics investigation completed/ARSIP program began
- Minuteman III guidance upgrade program implemented
- MK 12A reentry vehicle FOC
- Special operational test program began - Minuteman II
- Hardness critical items identified and procured
- ARSIP started
- Minuteman III MGS vibration test program initiated
- Special operational test program complete - accuracy improvements verified
- MESP IOC
- GUP implemented for Minuteman III
- Rivet MILE began
- Minuteman Long Range Planning (MLRP) process developed
- Peacekeeper deployment initiated
- Integrated Nuclear Effects Assessment (INEA)
- ARSIP implemented for Minuteman II
- Piece - parts manufacturing for diminishing manufacturing sources
- Rivet MILE began IMPSS installation
- Minuteman III Stage 2 washout/Stage 3 replacement
- Comprehensive reliability investigations conducted
- REACT program initiated
- Rocket Motor Transporter replacement
- Code Change Verifier Replacement
  - Transporter-Erector Replacement

# MINUTEMAN CHRONOLOGY (Cont'd)

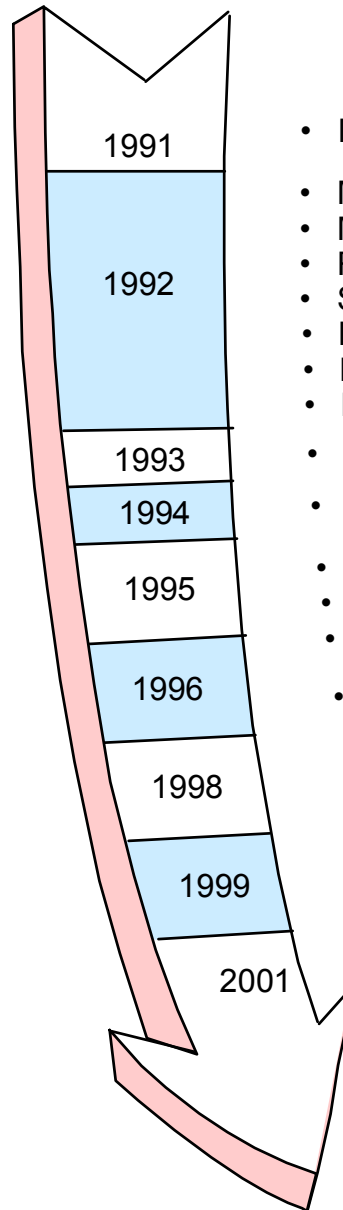

- Minuteman II removed from EWO
- Minuteman II deactivation initiated
- MESP discontinued
- Rivet MILE completed IMPSS installation
- SRV Program initiated
- Rivet ADD initiated
- Missile Transporter Replacement
- Missile Transporter (PT III) Replacement
- GRP contract awarded
- PRP initial contracts awarded
- REACT consoles began deployment
- Minuteman II deactivation complete
- BRAC decision to close Wing VI by 1998
- REACT deployment complete
- Wing VI deactivation complete, MM IIIs moved to Wing I
- AF awarded Prime Contract to TRW team for ICBM engineering
- First NS-50 MGC deployed
- PRP deployment initiated



# ACRONYM LIST

<b>20AF</b>	<b>Twentieth Air Force</b>	<b>EWO</b>	<b>Emergency War Order</b>
<b>A/D</b>	<b>Arm/Disarm</b>	<b>FCE</b>	<b>Flight Control Equipment</b>
<b>ABNCP</b>	<b>Airborne National Command Post</b>	<b>FDE</b>	<b>Force Development Evaluation</b>
<b>AC</b>	<b>Alternating Current</b>	<b>FLTSAT</b>	<b>Fleet Satellite System</b>
<b>ACG</b>	<b>Attitude Control Group</b>	<b>FOC</b>	<b>Final Operational Capability</b>
<b>AFMC</b>	<b>Air Force Materiel Command</b>	<b>G&amp;C</b>	<b>Guidance &amp; Control</b>
<b>AFPEO</b>	<b>Air Force Program Executive Office</b>	<b>GCA</b>	<b>Gyro Compass Assembly</b>
<b>AFSATCOM</b>	<b>Air Force Satellite Communication System</b>	<b>GIP</b>	<b>Guidance Improvement Program</b>
<b>AFSC</b>	<b>Air Force Systems Command</b>	<b>GRP</b>	<b>Guidance Replacement Program</b>
<b>AFSPC</b>	<b>Air Force Space Command</b>	<b>GSP</b>	<b>Gyro Stabilized Platform</b>
<b>ALCC</b>	<b>Airborne Launch Control Center</b>	<b>GSP</b>	<b>Gyro Stabilized Platform Program</b>
<b>ALCS</b>	<b>Airborne Launch Control System</b>	<b>GUP</b>	<b>Guidance Upgrade Program</b>
<b>AOTTS</b>	<b>All Ordnance Thrust Termination System</b>	<b>HICS</b>	<b>Hardened Intersite Cable System</b>
<b>APS</b>	<b>Auxiliary Power Supply</b>	<b>HQ AFMC</b>	<b>Headquarters, Air Force Materiel Command</b>
<b>ARSIP</b>	<b>Accuracy, Reliability, Supportability Improvement Program</b>	<b>HQ AFSPC</b>	<b>Headquarters, Air Force Space Command</b>
<b>AUTODIN</b>	<b>Automatic Digital Information Network</b>	<b>HQ USAF</b>	<b>Headquarters, United States Air Force</b>
<b>AVE</b>	<b>Aerospace Vehicle Equipment</b>	<b>ICBM</b>	<b>Intercontinental Ballistic Missile</b>
<b>BRAC</b>	<b>Base Realignment and Closure</b>	<b>ILCS</b>	<b>Improved Launch Control System</b>
<b>C&amp;S</b>	<b>Command &amp; Status</b>	<b>ILRP</b>	<b>ICBM Long-range Requirements Planning</b>
<b>CDB</b>	<b>Command Data Buffer</b>	<b>IMP</b>	<b>ICBM Master Plan</b>
<b>CP</b>	<b>Command Post</b>	<b>IMPSS</b>	<b>Improved Minuteman Physical Security System</b>
<b>DC</b>	<b>Direct Current</b>	<b>IMU</b>	<b>Inertial Measurement Unit</b>
<b>DCU</b>	<b>Digital Control Unit</b>	<b>INEA</b>	<b>Integrated Nuclear Effects Assessment</b>
<b>DoD</b>	<b>Department of Defense</b>	<b>IOC</b>	<b>Initial Operational Capability</b>
<b>DSCS</b>	<b>Defense Satellite Communication System</b>	<b>ISST</b>	<b>ICBM Super High Frequency Satellite Terminal</b>
<b>DSN</b>	<b>Defense Switching Network</b>	<b>LCC</b>	<b>Launch Control Center</b>
<b>EAM</b>	<b>Emergency Action Message</b>	<b>LCEB</b>	<b>Launch Control Equipment Building</b>
<b>EMP</b>	<b>Electromagnetic Pulse</b>	<b>LCF</b>	<b>Launch Control Facility</b>
<b>ENC</b>	<b>Exhaust Nozzle Control</b>	<b>LCSB</b>	<b>Launch Control Support Building</b>
<b>ERCS</b>	<b>Emergency Rocket Communication System</b>	<b>LEB</b>	<b>Launcher Equipment Building</b>
		<b>LER</b>	<b>Launch Equipment Room</b>



# **ACRONYM LIST (Cont'd)**

<b>LF</b>	<b>Launch Facility</b>	<b>PMRT</b>	<b>Program Management Responsibility Transfer</b>
<b>LITVC</b>	<b>Liquid Injection Thrust Vector Control</b>	<b>POM</b>	<b>Program Objective Memorandum</b>
<b>LSB</b>	<b>Launcher Support Building</b>	<b>PRP</b>	<b>Propulsion Replacement Program</b>
<b>LSC</b>	<b>Linear-Shaped Charge</b>	<b>PSRE</b>	<b>Propulsion System Rocket Engine</b>
<b>MAF</b>	<b>Missile Alert Facility</b>	<b>R&amp;D</b>	<b>Research &amp; Development</b>
<b>MCCM</b>	<b>Missile Combat Crew Member</b>	<b>RC</b>	<b>Roll Control</b>
<b>MEECN</b>	<b>Minimum Essential Emergency Communications Network</b>	<b>REACT</b>	<b>Rapid Execution and Combat Targeting</b>
<b>MESP</b>	<b>Minuteman Extended Survivable Power</b>	<b>Rivet MILE</b>	<b>Rivet Minuteman Integrated Life Extension</b>
<b>MF</b>	<b>Medium Frequency</b>	<b>RS</b>	<b>Reentry System</b>
<b>MGS</b>	<b>Missile Guidance Set</b>	<b>RV</b>	<b>Reentry Vehicle</b>
<b>MGSC</b>	<b>Missile Guidance Set Control</b>	<b>S&amp;A</b>	<b>Safing &amp; Arming</b>
<b>MILSTAR</b>	<b>Military Strategic, Tactical and Relay</b>	<b>SA-ALC</b>	<b>San Antonio Air Logistics Center</b>
<b>MIRV</b>	<b>Multiple Independently Targetable Reentry Vehicle</b>	<b>SACCS</b>	<b>Strategic Automated Command and Control System</b>
<b>MLRP</b>	<b>Minuteman Long Range Planning</b>	<b>SAF</b>	<b>Secretary of the Air Force</b>
<b>MM</b>	<b>Minuteman</b>	<b>SCT</b>	<b>Shielded Cable Tester</b>
<b>MMP</b>	<b>Minuteman MEECN Program</b>	<b>SECDEF</b>	<b>Secretary of Defense</b>
<b>MMRT</b>	<b>Modified Miniature Receiver Terminal</b>	<b>SERV</b>	<b>Safety Enhanced Reentry Vehicle</b>
<b>MOM</b>	<b>Modified Operational Missile</b>	<b>SHF</b>	<b>Super High Frequency</b>
<b>MTBF</b>	<b>Mean Time Between Failure</b>	<b>SLFCS</b>	<b>Survivable Low Frequency Communication System</b>
<b>NAOC</b>	<b>National Airborne Operations Center</b>	<b>SPD</b>	<b>System Program Director</b>
<b>NCU</b>	<b>Nozzle Control Unit</b>	<b>SPO</b>	<b>System Program Office</b>
<b>NH&amp;S</b>	<b>Nuclear Hardness &amp; Survivability</b>	<b>SRV</b>	<b>Single Reentry Vehicle</b>
<b>OGE</b>	<b>Operational Ground Equipment</b>	<b>SSAS</b>	<b>Software Status Authentication System</b>
<b>OO-ALC</b>	<b>Ogden Air Logistic Center</b>	<b>TE</b>	<b>Transporter-Erector</b>
<b>PBV</b>	<b>Post-Boost Vehicle</b>	<b>TT</b>	<b>Thrust Terminator</b>
<b>PIG</b>	<b>Pendulous Integrating Gyroscope</b>	<b>TVC</b>	<b>Thrust Vector Control</b>
<b>PIGA</b>	<b>Pendulous Integrating Gyroscopic Accelerometer</b>	<b>UHF</b>	<b>Ultra High Frequency</b>
<b>PIMS</b>	<b>Peacekeeper in Minuteman Silo</b>	<b>USSTRATCOM</b>	<b>US Strategic Command</b>
<b>PK</b>	<b>Peacekeeper</b>	<b>VLF</b>	<b>Very Low Frequency</b>
<b>PLC</b>	<b>Preparatory Launch Command</b>	<b>VRSA</b>	<b>Voice Reporting Signal Assembly</b>